

FLUSHWOOD MEDIUM SPART PARTS - SEPTEMBER 2019

Door Parts

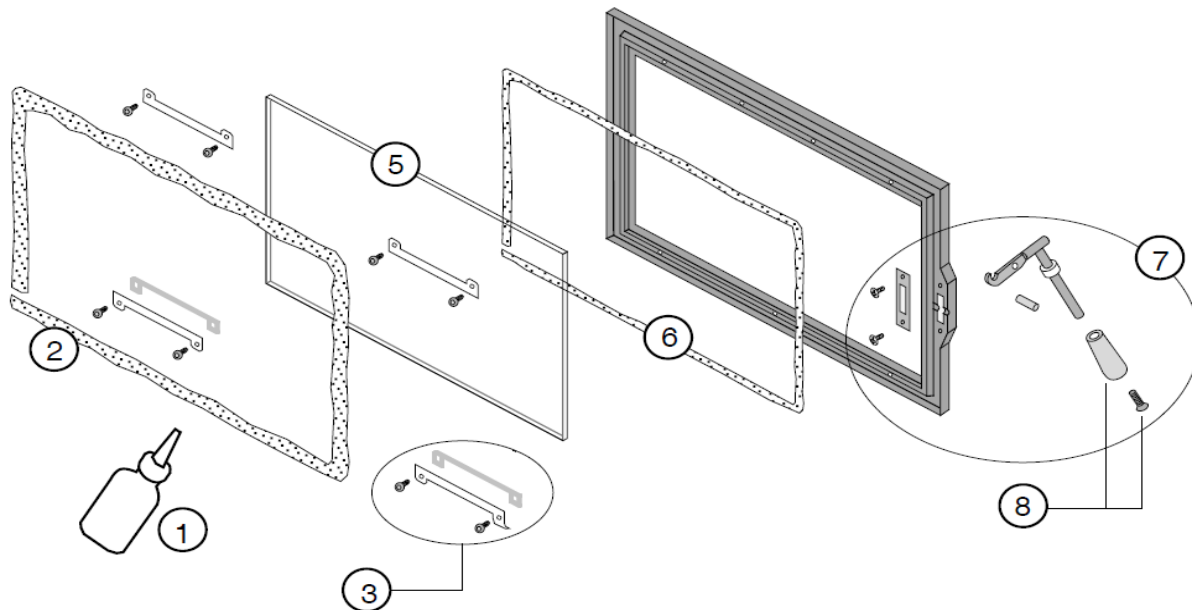

Pricing shown excludes freight and installation. Pricing may vary depending on area.

Pricing includes GST.

ID #	Description	Qty	Part #	\$	Other Detail
1	Gasket Cement, 4oz				See your LOPI Dealer
2	Door Gasket, 3/8" x 70"	1	99900429	\$ 50	
3	Glass Clips with Gaskets and Screws (4)	1	250-02191	\$ 11	
5	Glass with Gasket	1	250-02183	\$200	
6	Glass Gasket (1/4" x 65")	1	250-02184	\$ 14	
7	Handle Assembly	1	250-02196	\$ 43	
8	Wood Handle with Screw	1	250-01305	\$ 25	

Replacing the Glass



The glass must not contact the door retainer or glass clips directly. The glass gasket and glass clip gaskets insulate the glass to prevent cracking. Do not over-tighten the glass clips.

Lay the glass gasket in the door frame (cut off excess gasket). Place the glass on the gasket. Secure the glass clips to hold the glass in place (make sure the glass clip gaskets are in place).

Replacing the Door Gasket

The door gasket inserts into the outer groove of the door retainer. Stove gasket cement holds it in place. Before installing, remove any residual cement. Lay the gasket in place (start at the lower left corner) and cut off any excess gasket (do not stretch the gasket. The cement fully cures with heat from the stove. You may need to open and close the door repeatedly to get the gasket to seat fully.

Firebox Parts

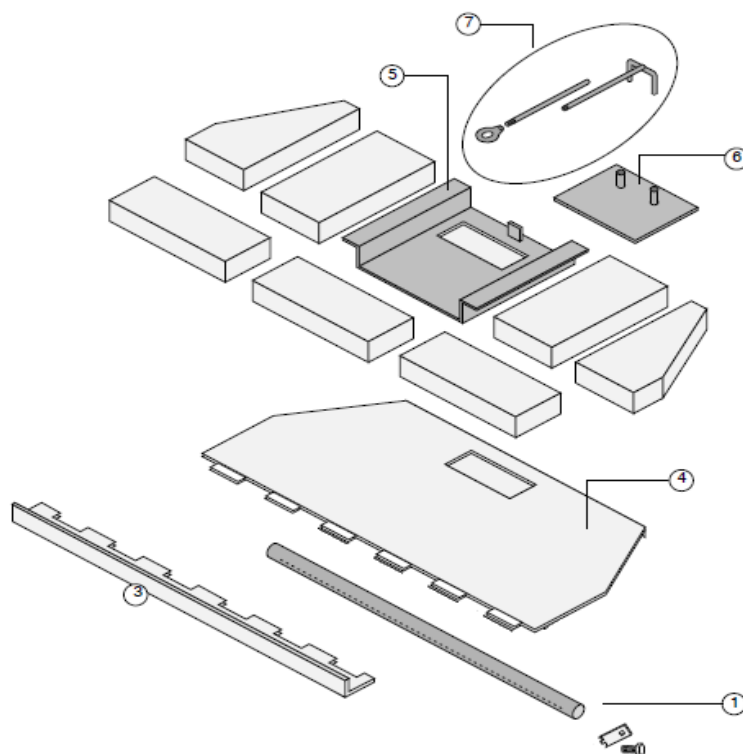

Pricing shown excludes freight and installation. Pricing may vary depending on area.

Pricing includes GST.

ID #	Description	Qty	Part #	\$	Other Detail
1	Secondary Air Tube with Pin L-24	1	98900243	\$ 81	
3	Baffle Front	1	250-02187	\$ 54	
4	Baffle Plate	1	250-02188	\$143	
5	Bypass/Damper Plate	1	250-02202	\$ 47	
6	Damper Slider	1	250-02203	\$ 39	
7	Damper Yoke with Extension Rod	1	250-02189	\$ 36	
7	Pull Ring	1	250-00499	\$ 25	

Baffle Removal

- 1 Remove the face to prevent damage. Remove the door (lift off hinges).
- 2 Remove the front two air tubes (see "Air Tube Removal & Replacement" on the following page).
- 3 Remove front row of bricks.
- 4 Unscrew the damper rod extension from damper yoke and slide it forward to remove (you may need to use pliers to unscrew the rod).
- 5 Lift the damper yoke up to disengage it from the damper plate. The yoke may be left in place or unscrewed and removed if needed.
- 6 Remove the bypass plate and damper assembly by pulling forward and leaning the front edge down.
- 7 Remove the four rear bricks.
- 8 Remove baffle front and baffle plate (rotate it forward).