

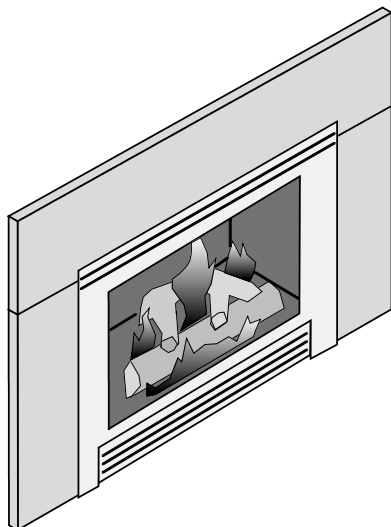

**TRAVIS INDUSTRIES
HOUSE OF FIRE**



DVS GSR2 (AU) Inbuilt NB GREEN SMART™ Owner's Manual



AS/NZS 5263.1.3
GMK10034
IAPMO-R&T OCEANA



- Direct Vent Fireplace Insert
- Masonry or Factory Built (Metal) Wood-Burning Fireplace
- Residential or Mobile Home

WARNING: If the information in these instructions is not followed exactly, a fire or explosion may result causing property damage, personal injury or loss of life.

- DO NOT PLACE ARTICLES ON OR AGAINST THIS APPLIANCE.
- DO NOT USE OR STORE FLAMMABLE MATERIALS NEAR THIS APPLIANCE.
- DO NOT SPRAY AEROSOLS IN THE VICINITY OF THIS APPLIANCE WHILE IT IS IN OPERATION.
- DO NOT MODIFY THIS APPLIANCE.
- Do not store or use gasoline or other flammable vapors and liquids in the vicinity of this or any other appliance.

WHAT TO DO IF YOU SMELL GAS

- Do not try to light any appliance.
- Do not touch any electrical switch; do not use any phone in your building.
- Immediately call gas supplier from a neighbor's phone. Follow the gas supplier's instructions.
- If you cannot reach your gas supplier, call the fire department.
- Installation and service must be performed by a qualified installer, service agency or the gas supplier.

This appliance may be installed in an aftermarket, permanently located, manufactured home (USA only) or mobile home, where not prohibited by local codes.

This appliance is only for use with the type(s) of gas indicated on the rating plate. A conversion kit is supplied with the appliance.

INSTALLER: Leave this manual with the appliance.

CONSUMER: Retain this manual for future reference.

Dragon Wholesaling Pty. Ltd.
Unit 4, 16 Lexington Drive
Bella Vista NSW 2153
Australia

Introduction

We welcome you as a new owner of a DVS Insert. In purchasing this fireplace insert you have joined the growing ranks of concerned individuals whose selection of an energy system reflects both a concern for the environment and aesthetics. It is one of the finest home heaters the world over. This manual will explain the installation, operation, and maintenance of this heater. Please familiarize yourself with the Owner's Manual before operating your heater and save the manual for future reference. Included are helpful hints and suggestions that will make the operation and maintenance of your new heater an easier and more enjoyable experience. We offer our continual support and guidance to help you achieve the maximum benefit and enjoyment from your heater.

Important Information

No other DVS Insert has the same serial number as yours. The serial number is attached to the appliance near the gas control valve.

This serial number will be needed in case you require service of any type.

Model: DVS GSR2 NB

Serial Number: _____

Purchase Date: _____

Purchased From: _____

<u>Introduction</u>	2	<u>Before You Begin</u>	25
<u>Important Information</u>	2	Remote Control Warnings	25
<u>Features</u>	6	<u>Remote Set-Up</u>	26
<u>Installation Options</u>	6	Verify the Switch is on “REMOTE”	26
<u>Heating Specifications</u>	6	Synchronize the Transmitter to the IFC	26
<u>Dimensions</u>	6	Clearing the System Memory	26
<u>Fuel</u>	6	<u>Location of Controls</u>	27
<u>Installation Warnings</u>	7	<u>Direct Operation</u>	27
<u>Packing List</u>	7	<u>Starting the Fireplace for the First Time</u>	28
<u>Additional Items Required</u>	8	<u>Continuous/Intermittent Pilot Switch</u>	28
<u>Items Packed with the Face</u>	8	Switching from Intermittent (IPI) to Continuous Pilot (CPI).....	28
<u>Order of Installation</u>	8	<u>Remote Operation</u>	29
<u>Top Convection Deflector</u>	9	Display Overview	29
<u>Fireplace Requirements</u>	9	Listen for the “Beep”	29
Factory-Built (Metal) Wood-Burning Fireplace Requirements.....	10	<u>Manual On-Off / Smart Thermostat / Standard Thermostat</u>	30
<u>Fireplace Altered Tag</u>	10	<u>Mode Controls (Flame, Blower, Light, Comfort Control)</u>	31
<u>Hearth Requirements</u>	10	Flame Height.....	31
<u>Leveling Bolts</u>	11	Blower Speed.....	31
<u>Electrical Requirements</u>	11	<u>Mode Controls - continued</u>	32
<u>Clearances</u>	12	Accent Light	32
Mantel Clearances	12	Comfort Control (rear burner)	32
<u>Modifying the Face Connector for Discovery, Rosario, and Artisan Faces</u>	12	<u>Display Fahrenheit or Celsius</u>	32
<u>Gas Line Requirements</u>	13	<u>Low Battery Indicator</u>	33
Gas Line Location	13	Transmitter Batteries.....	33
Gas Inlet Pressure	13	IFC Batteries	33
<u>Vent Requirements</u>	14	<u>Battery Replacement</u>	33
Altitude Considerations	14	Battery Installation	33
Vent Restrictor	15	Transmitter Battery Installation	33
Vent Installation	15	<u>Power Outages</u>	33
Vent Location	16	<u>Child-Proof Feature</u>	34
Vent Configurations	16	<u>Normal Operating Sounds</u>	34
Vent Connector Removal and Installation.....	17	<u>Normal Operating Odors</u>	34
Vent Connector Removal and Installation (continued)	18	<u>Maintaining Your Heater's Appearance</u>	35
<u>Surround Panel Installation</u>	19	<u>Accent Light Replacement</u>	35
3-Piece Surround Panels	19	Lower Accent Light.....	35
1-Piece Surround Panel	20	<u>Yearly Service Procedure</u>	36
Routing the Power Cord	20	<u>Troubleshooting Table</u>	37
Installation	20	<u>Wiring Diagram</u>	38
<u>Glass Frame Removal and Installation</u>	21	<u>Replacement Parts List</u>	38
<u>Glass Frame Removal and Installation (continued)</u>	22	Safety Label.....	39
<u>Steps for Finalizing the Installation</u>	23	<u>CONDITIONS & EXCLUSIONS</u>	40
Air Shutter Adjustment	24	<u>IF WARRANTY SERVICE IS NEEDED:</u>	40
		<u>LP Conversion Instructions</u>	41

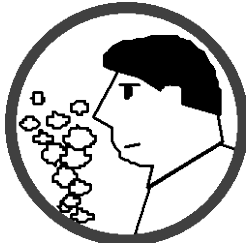
**IF YOU SMELL GAS:**

- * Do not light any appliance
- * Extinguish any open flame
- * Do not touch any electrical switch or plug or unplug anything
- * Open windows and vacate building
- * Call gas supplier from neighbor's house, if not reached, call fire department



This unit must be installed by a qualified installer to prevent the possibility of an explosion. Your dealer will know the requirements in your area and can inform you of those people considered qualified. The room heater should be inspected and cleaned before use and at least annually by a qualified service person. More frequent cleaning may be required due to excessive lint from carpeting, bedding material, etc.

The instructions in this manual must be strictly adhered to. Do not use makeshift methods or compromise in the installation. Improper installation will void the warranty and safety listing.

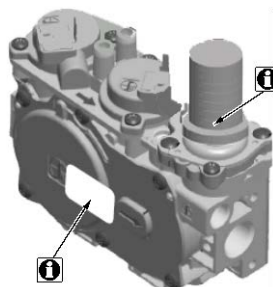

This heater is either approved for natural gas (NG) or for propane (LP). Burning the incorrect fuel will void the warranty and safety listing and may cause an extreme safety hazard. Direct questions about the type of fuel used to your dealer. Check for a label on the flame adjust knob on the gas control valve (this is the best place to check). You may also check for a label on the gas control valve body.



Contact your local building officials to obtain a permit and information on any installation restrictions or inspection requirements in your area. Notify your insurance company of this heater as well.



If the flame becomes sooty, dark orange in color, or extremely tall, do not operate the heater. Call your dealer and arrange for proper servicing.

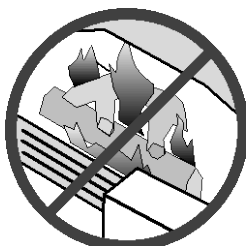

It is imperative that control compartments, screens, or circulating air passageways of the heater be kept clean and free of obstructions. These areas provide the air necessary for safe operation.



Do not operate the heater if it is not operating properly in any fashion or if you are uncertain. Call your dealer for a full explanation of your heater and what to expect.



Do not store or use gasoline or other flammable liquids in the vicinity of this heater.



Do not operate if any portion of the heater was submerged in water or if any corrosion occurs. Immediately call a qualified service technician to inspect the appliance and to replace any part of the control system that has been under water.



- Do not place clothing or other flammable items on or near the heater. Because this heater can be controlled by a thermostat there is a possibility of the heater turning on and igniting any items placed on or near it.



- Light the heater using the built-in igniter. Do not use matches or any other external device to light your heater.
- Allow the heater to cool before carrying out any maintenance or cleaning.

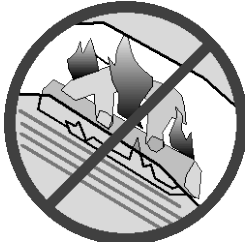

- Viewing glass should only be removed for service. Any safety screen or guard removed for servicing must be replaced prior to operating the heater. Do not operate with the glass removed or damaged. Replacement of the glass should be done by a licensed or qualified service person.

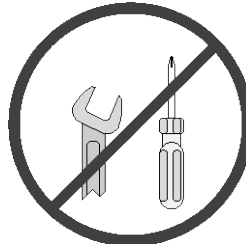

- Never remove, replace, modify or substitute any part of the heater unless instructions are given in this manual. All other work must be done by a trained technician. Don't modify or replace orifices. Replace glass with Travis glass only.



- Operate the heater according to the instructions included in this manual.
- If the main burners do not start correctly turn the gas off and call your dealer for service.

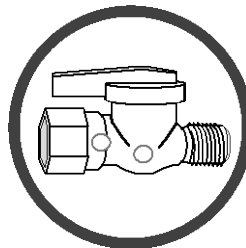

- Instruct everyone in the house how to shut gas off to the appliance and at the gas main shutoff valve. The gas main shutoff valve is usually next to the gas meter or propane tank and requires a wrench to shut off.



- This unit is not for use with solid fuel
- Do not place anything inside the firebox (except the included fiber logs).
- If the fiber logs become damaged, replace with Travis Industries log set.

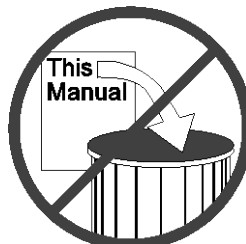

- Do not throw this manual away. This manual has important operating and maintenance instructions that you will need at a later time. Always follow the instructions in this manual.

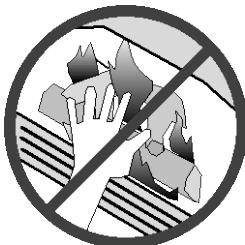

- Young children should be carefully supervised when they are in the same room as the appliance. Toddlers, young children and others may be susceptible to accidental contact burns. A physical barrier is recommended if there are at risk individuals in the house. To restrict access to a fireplace or stove, install an adjustable safety gate to keep toddlers, young children and other at risk individuals out of the room and away from hot surfaces.

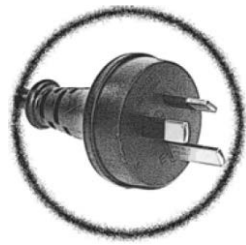

- Plug the heater into a 240V grounded electrical outlet. Do not remove the grounding plug.
- Don't route the electrical cord in front of, over, or under the heater

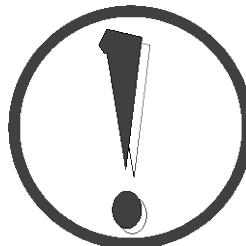

- **Travis Industries, Inc. grants no warranty, implied or stated, for the installation or maintenance of your heater, and assumes no responsibility of any consequential damage(s).**

Features

- Works During Power Outages (battery backup system)
- Blower and Remote Control Included
- Standing or Intermittent (GreenSmart 2) Pilot
- Convenient Operating Controls
- Variable-Rate Heat Output
- Accent Light

Installation Options

- Residential or Mobile Home
- Fireplace Insert
- Masonry or Factory Built (Metal) Wood-Burning Fireplace
- Natural Gas or Propane

Heating Specifications

	Natural Gas	Propane
Maximum Input (Mj/h)	32.7	32.7

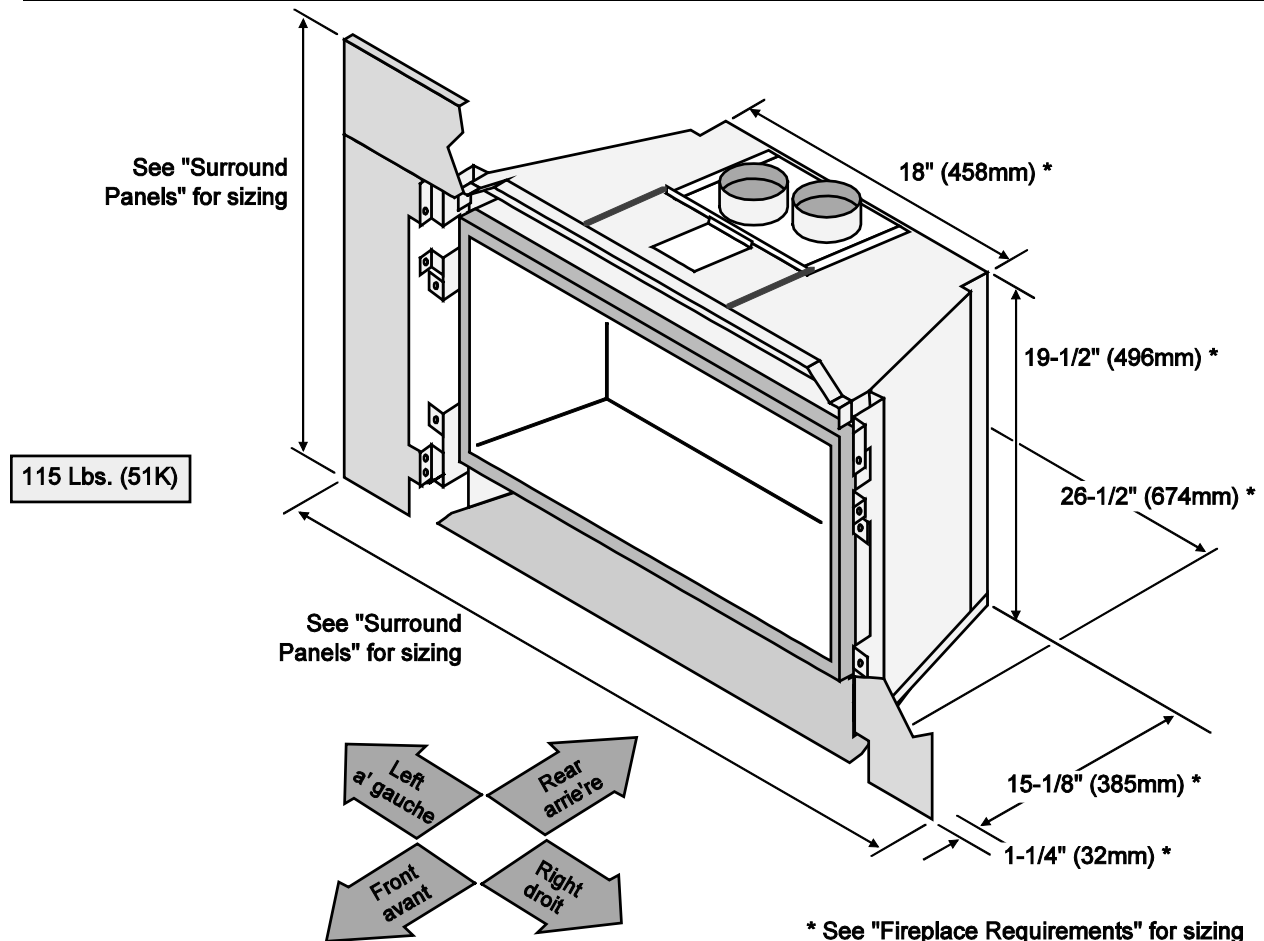
Dimensions

* See "Fireplace Requirements" for sizing details with 1-piece or 3-piece panels.

Fuel

This heater is shipped in natural gas (NG) configuration but may be converted to use propane (LP) using a conversion kit. The sticker on top of the gas control valve will verify the correct fuel.

Installation Warnings

- Failure to follow all of the requirements may result in property damage, bodily injury, or even death.
- This heater must be installed by an authorized installer who has gone through a training program for the installation of direct vent gas appliances.
- This appliance must be installed in accordance with the manufacturer's installation instructions, local gas fitting regulations, municipal building codes, water supply regulations, electrical wiring regulations, AS 5601 / AG 601—2000, *Gas installations* and any other relevant statutory regulations. In Australia follow AS/NZS 5601.1.
- This heater is either approved for natural gas (NG) or for propane (LP). Burning the incorrect fuel will void the warranty and safety listing and may cause a house fire. Direct questions about the type of fuel used to your dealer. To determine which fuel your heater is using, check for a label on the flame adjust knob on the gas control valve (this is the best place to check). You may also check for a label on the gas control valve body.
- All exhaust gases must be vented outside the structure of the living-area. Combustion air is drawn from outside the living-area structure.
- Notify your insurance company before hooking up this heater.
- The requirements listed below are divided into sections. All requirements must be met simultaneously. The order of installation is not rigid – the authorized installer should follow the procedure best suited for the installation.

SAFETY WARNINGS:

- **DO NOT PLACE ARTICLES ON OR AGAINST THIS APPLIANCE.**
- **DO NOT USE OR STORE FLAMMABLE MATERIALS NEAR THIS APPLIANCE.**
- **DO NOT SPRAY AEROSOLS IN THE VICINITY OF THIS APPLIANCE WHILE IT IS IN OPERATION.**
- **DO NOT MODIFY THIS APPLIANCE.**
- **THIS INSTALLATION MUST CONFORM WITH THE FOLLOWING:**
 - Manufacturer's Installation instructions
 - Local Gas Fitting Regulations
 - Municipal Building Codes,
 - Refer to AS/NZS 5601.1 for Gas Installations.
 - S.A.A. Wiring Code
 - Local Electrical Regulations
 - Any other statutory regulations
- **NOT SUITABLE FOR MARINE USE.**
- **NOT INTENDED FOR FIREPLACE INSERT.**
- **APPLIANCES INCORPORATING A LIVE FUEL EFFECT, AND DESIGNED TO OPERATE WITH LUMINOUS FLAMES, MAY EXHIBIT SLIGHT CARBON DEPOSITION.**

Packing List

- LP Conversion Parts (Orifices, etc.)
- Cove Covers
- "Fireplace Altered" tag (attach to the fireplace)
- Cover Plugs for 3-Piece Surround Panels
- Remote Control
- Top Convection Deflector

Additional Items Required

- **If using LP (propane) a conversion kit is required (sku 94400999 – GSR Stepper Motor Kit)**
- Faceplate
- Chimney Liner and Termination Kit
- Gas Line Equipment

- **This Insert Requires a Burner Kit and Media (logs/stones)**

This fireplace is shipped without a burner. This allows the fireplace to be configured in unique designs. See the table below to verify you have all of the items required.

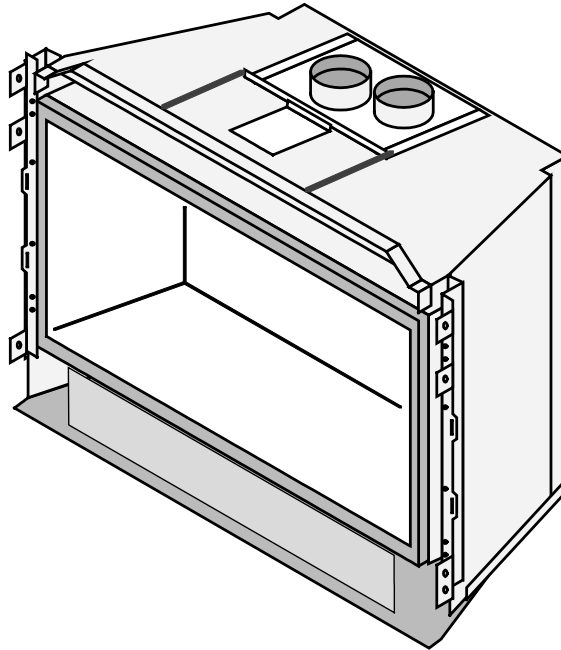

<u>Burner Style</u>	<u>EmberFyre™ Burner</u>	<u>DancingFyre™ Burner</u>
	96900102	96900103
<u>Media</u>	Logs Included w Burner	Driftwood Log Set (sku 94500548) Fyre-Stone Stone Set (sku 94700732) Log Set (sku 94400991) Stone Set (sku 94700729)

Items Packed with the Face

- Face with attachment hardware (Note: use the cove covers included with the heater)
- Face Installation Instructions

Order of Installation

- 1 If the heater is to use propane, install the propane conversion kit (see page 41).
- 2 Install gas line into the fireplace (do not connect to unit).
- 3 Position the heater and connect the electrical line.
- 4 Connect the gas line and gas vent to the appliance.
- 5 Install the optional surround panels and trim.
- 6 Install the burner and media (logs and stones).
- 7 Follow the instructions under "Finalizing the Installation" on page 23.

Top Convection Deflector

Install the top convection deflector as shown to the right.

The deflector is shipped on top of the insert. The screws are shipped inside the owner's pack.

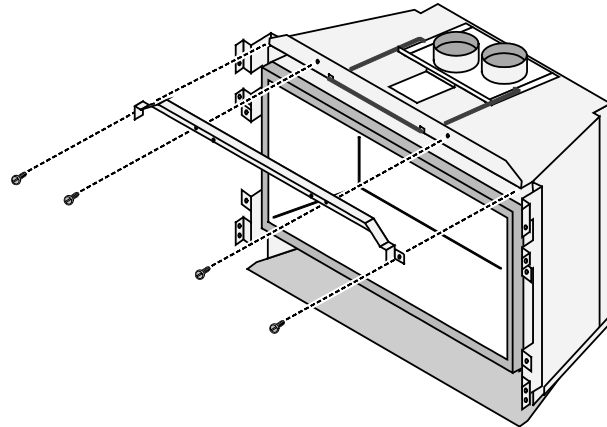

Fireplace Requirements

- Insert must be placed within a code-conforming masonry fireplace or tested and listed factory-built (metal) wood-burning fireplace. Repair any fireplace damage prior to installation.
- Because the insert uses a circulation blower, clean the fireplace, smoke shelf, and chimney prior to installation.
- This heater may be placed in a bedroom. Please be aware of the large amount of heat this appliance produces when determining a location.

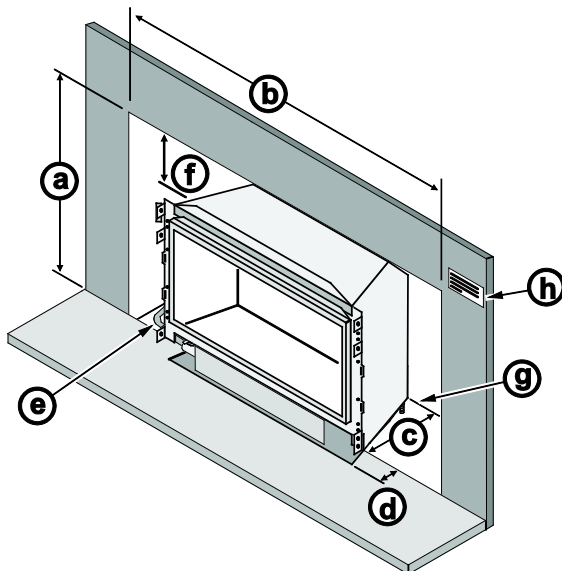

Fireplace Sizing	3-Piece Panel	1-Piece Panel
(a) Minimum Height	19-1/2" (496mm)	20-5/8" (524mm)
(b) Minimum Width	26-1/2" (674mm)	29" (737mm)
(c) Minimum Depth	15-1/8" (385mm)	16-3/8" (416mm)
(d) Hearth Extension	1-1/4" (32mm)	0" (0mm)

- (e)** The gas and electrical line should be installed prior to installing the heater.
- (f)** For tight fits (under 24" 610mm) see the section "Removing the Vent Connector"
- (g)** See "Leveling Bolts" for details on leveling the heater.

- (h)** Attach the "This fireplace has been altered..." plate to the fireplace (use two screws or other suitable method). You may wish to place it in a location where it will be covered by the surround panels.

Factory-Built (Metal) Wood-Burning Fireplace Requirements

NOTE: Any parts that are removed must be removed in a way that would allow them to be re-installed if the insert is ever removed (removal of rivets or screws is acceptable).

The damper ("A") and grate (with log set) ("B") must be removed (see the illustration below)

The smoke shelf ("C"), internal baffles ("D"), screen ("E"), masonry lining or refractory ("G" & "I"), and metal or glass doors ("F") may be removed (if applicable)

The fireplace must be permanently marked to indicate that it has been altered and is no longer suitable for burning solid fuel (wood), unless the removed parts are re-installed. Cutting of any metal or glass parts is prohibited.

The insulation ("H"), and any structured rigid frame members must not be removed or altered (side and top of door frame, side and top of the face of the fireplace, metal sides, etc.).

The metal floor ("J") may be removed to allow additional room for installation of the insert. If the floor is removed the insert must be placed directly on the metal base of the metal fireplace.

The surround panels should not seal ventilation openings on the fireplace.

If the factory-built fireplace has no gas access hole(s) provided, an access hole (one inch or less) may be drilled through the lower sides or bottom of the firebox in a proper workmanship like manner. This access hole must be plugged with non-combustible insulation after the gas supply line has been installed.

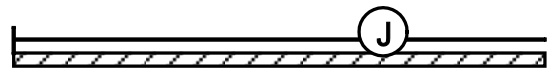
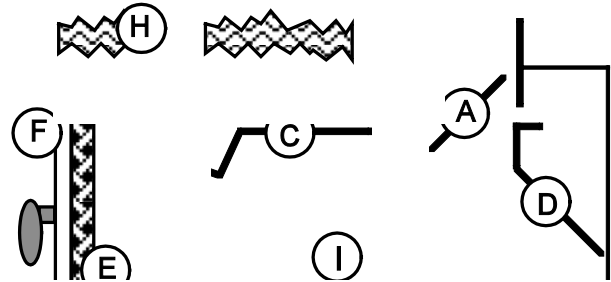

Fireplace Altered Tag

Attach the "This fireplace has been altered..." plate to the fireplace (use two screws or other suitable method). You may wish to place it in a location where it will be covered by the surround panels.

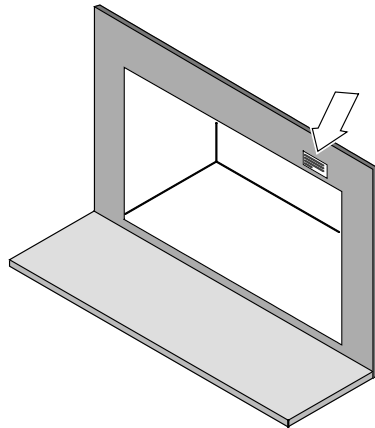

Hearth Requirements

The heater and face must not contact combustible surfaces. A non-combustible hearth extension is not required. However, if the heater is installed next to the floor, we recommend a hearth to protect the flooring surface from discoloration or other negative impact from the heater.

Leveling Bolts

This heater includes front and rear leveling bolts to accommodate fireplaces with a step-down firebox.

NOTE: To access the rear leveling bolts, remove the cover plates and gaskets (replace after adjustment).

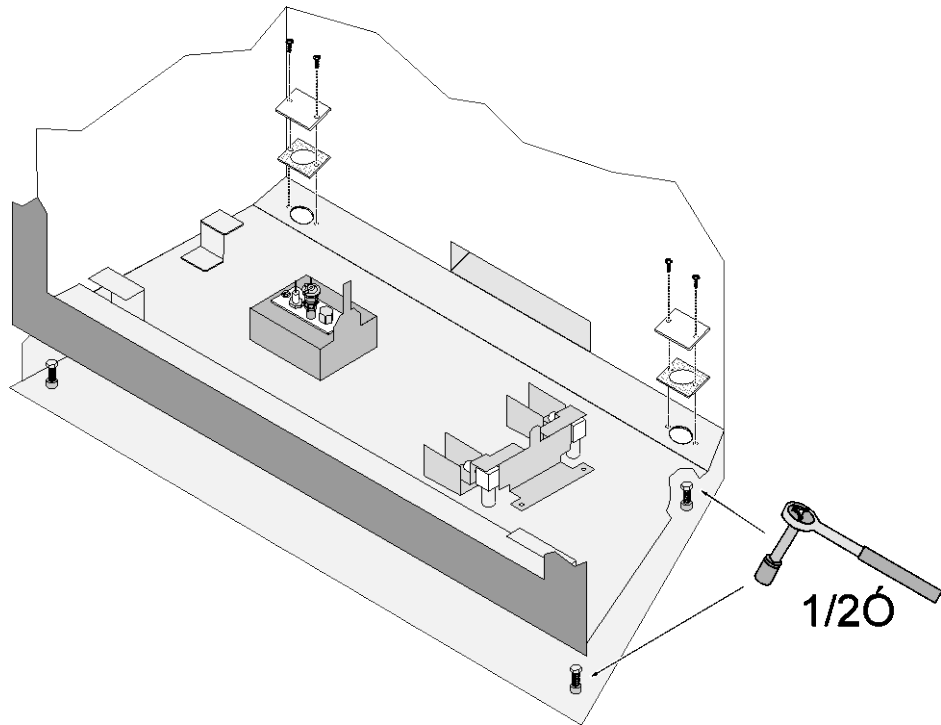

Electrical Requirements

- Route the power cord out of the access hole on the right side of the appliance.
- Plug the power cord into a grounded 240 Volt outlet (do not remove the grounding pin).
- The electrical connection may also be made using the optional Wiring Kit (SKU 97200315).

Clearances

Due to the high temperature of the heater, it should be located out of traffic and away from furniture and draperies.

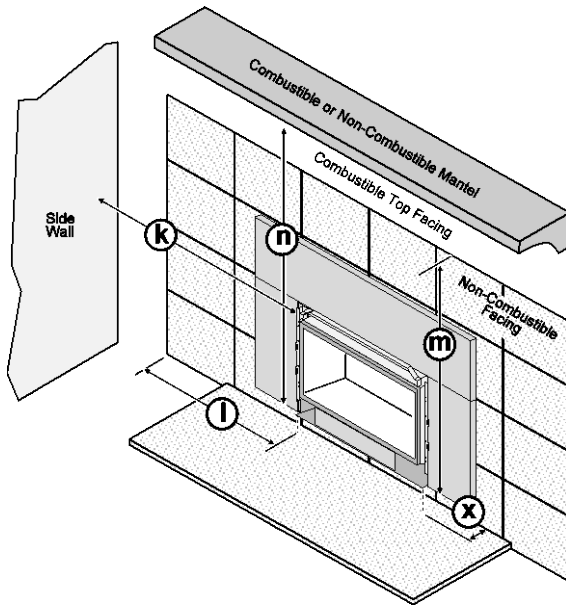

	Minimum Clearances
k Sidewall to Insert	4-1/2" 115mm
l Side Facing (non-combustible)	4-1/2" 115mm
m Top Facing* (non-combustible)	35" 889mm
n Mantel* (combustible or non-combustible)	35" 889mm
x Hearth Extension (3-Piece Panel)	1-1/4" 32mm
x Hearth Extension (1-Piece Panel)	0" 0mm

* Measured from the base of the insert.

Mantel Clearances

The maximum mantel depth is 12" (305mm).

NOTE: The combustible area above the facing must not protrude more than 3/4" (20mm) from the facing. If it does, it is considered a mantel and must meet the mantel requirements listed in this manual.

Modifying the Face Connector for Discovery, Rosario, and Artisan Faces

The Discovery, Rosario, and Artisan face require re-positioning of the face connector. See the directions below for details.

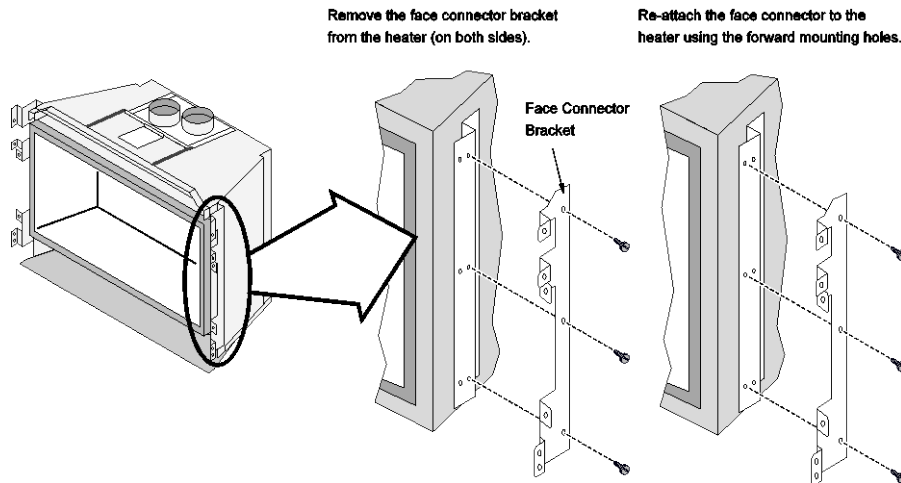

Gas Line Requirements

MASSACHUSETTS INSTALLATIONS - **WARNING:**

THIS PRODUCT MUST BE INSTALLED BY A LICENSED PLUMBER OR GAS FITTER WHEN INSTALLED WITHIN THE COMMONWEALTH OF MASSACHUSETTS.

OTHER MASSACHUSETTS CODE REQUIREMENTS:

- Flexible connector must not be longer than 36 inches.
- Shutoff valve must be a "T" handle gas cock.
- Only direct vent sealed combustion products are approved for bedrooms or bathrooms.
- Fireplace dampers must be removed or welded in the open position prior to the installation of a fireplace insert or gas log.
- A carbon monoxide (CO) detector is required in the same room as the appliance.

- The gas line must be installed in accordance with all local codes and the requirements listed below. In the absence of local codes, follow ANSI 223.1 in US/Canada or AS/NZS 5601.1 in Australia.
- A manual shutoff valve is required within 3' of the heater. It should be placed upstream of the flex line (if used) and may be installed behind the access door inside the heater.).
- The heater and gas control valve must be disconnected from the gas supply piping during any pressure testing of that system at test pressures in excess of 1/2 psig. For pressures under 1/2 psig, isolate the gas supply piping by closing the manual shutoff valve.
- Leak test all gas line joints and the gas control valve prior to and after starting the heater.
- This heater is designed either for natural gas or for propane (but not for both). Check the sticker on the top of the gas control valve to make sure the correct fuel is used (see illustration on page 4).
- Installation must be performed by a qualified installer, service agency or the gas supplier (In Massachusetts a licensed plumber/gasfitter).

Gas Line Location

- The gas inlet accepts a 1/2" MPT.

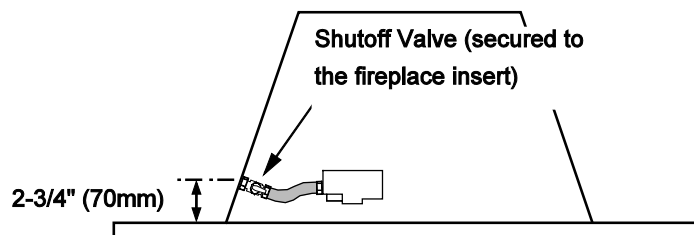

Gas Inlet Pressure

	Standard Input Pressure
Natural Gas	1.74 kPa (Min. 1.13 kPa)
Propane	2.74 kPa

- If the pressure is not sufficient, make sure the piping used is large enough, the supply regulator is adequately adjusted, and the total gas load for the residence does not exceed the amount supplied.
- The supply regulator (the regulator that attaches directly to the residence inlet or to the propane tank) should supply gas at the suggested input pressure listed above. Contact the local gas supplier if the regulator is at an improper pressure.

Vent Requirements

Travis Industries manufactures a vent kit specifically for this insert (sku 96200330). It includes 30' (10M) of vent, hose clamps, and a prairie cap. The flashing on the cap is 18" (458mm) by 18" (458mm).

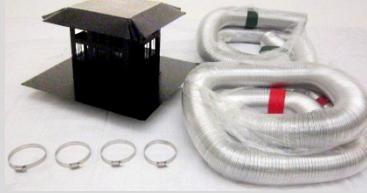

- The gas appliance and vent system must be vented directly to the outside of the building, and never be attached to a chimney serving a separate solid fuel or gas-burning appliance. Each direct vent gas appliance must use its own separate vent system.
- Make sure the exhaust pipe on the heater connects to the exhaust portion of the cap. The illustrations below show how the flex liners should be attached.
- The exhaust vent must reline the entire length of the chimney and terminate above the chimney top.
- Be careful not to crimp or rupture the liner when bending it into chimney offsets.
- When installed, the vent must meet all of the vent manufacturer's requirements.
- Use the following vent:
 - 3" UL 441 or 1777 Gas Liner for Exhaust and Air Inlet
 - Duravent Chimney Liner Termination Kit (3" & 3" Co-Linear to 6-5/8" Co-Axial w Flashing)
 - Simpson Duravent High-Wind Vertical Termination Cap (46DVA-VCH) or Prairie Cap

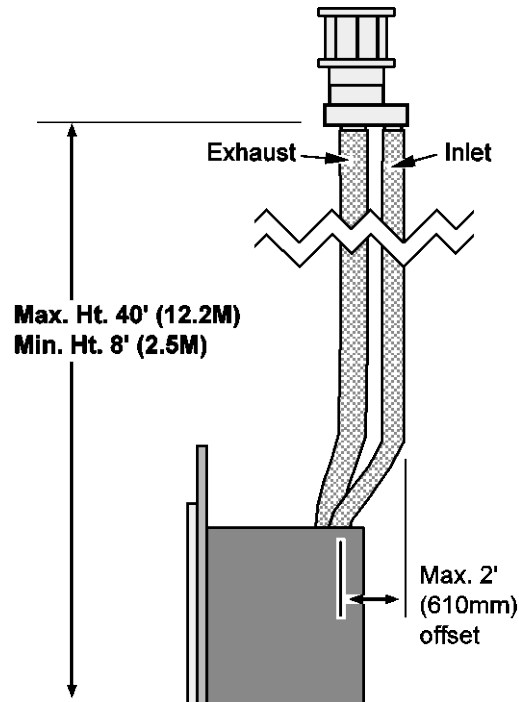

Altitude Considerations

- This heater has been tested at altitudes ranging from sea level to 6,000 feet (1,800 M). In this testing we have found that the heater, with its standard orifice, burns correctly with just an air shutter adjustment.
- Failure to adjust the air shutter properly may lead to improper combustion which can create a safety hazard. Consult your dealer or installer if you suspect an improperly adjusted air shutter.

Vent Restrictor

WARNING: Restrictor adjustment should only be done by a qualified installer.

Only those installations determined to be over-drafting require this adjustment. The best indication of over-drafting is a hyper-active flame pattern (flames that move too quickly). If the air shutter is constricted, the flames become short and yellow, yet still very active. Over-drafting may affect the pilot, but this is not the best way to determine over-drafting. Over-drafting is most likely in tall venting configurations. Do not over-restrict the vent (this leads to ghosting or lifting flames - reduce restrictor setting).

The restrictor is adjusted with the face removed. Start with the restrictor in position number 1. Monitor the flame for 5 minutes before adjusting. Move the restrictor a maximum two positions at a time by lifting the adjustment plate and moving it until the correct notch falls into the slot on the adjustment bracket (use a glove if the heater is hot - see illustration below). Monitor the flame for 5 minutes to determine correct restrictor position and repeat restrictor adjustment if necessary.

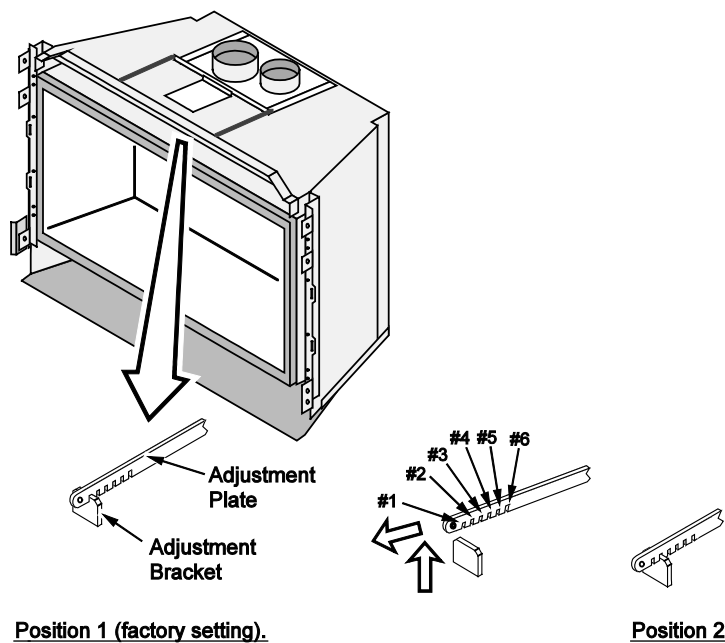

Vent Installation

Secure the vent to the fireplace insert and termination kit using screws.

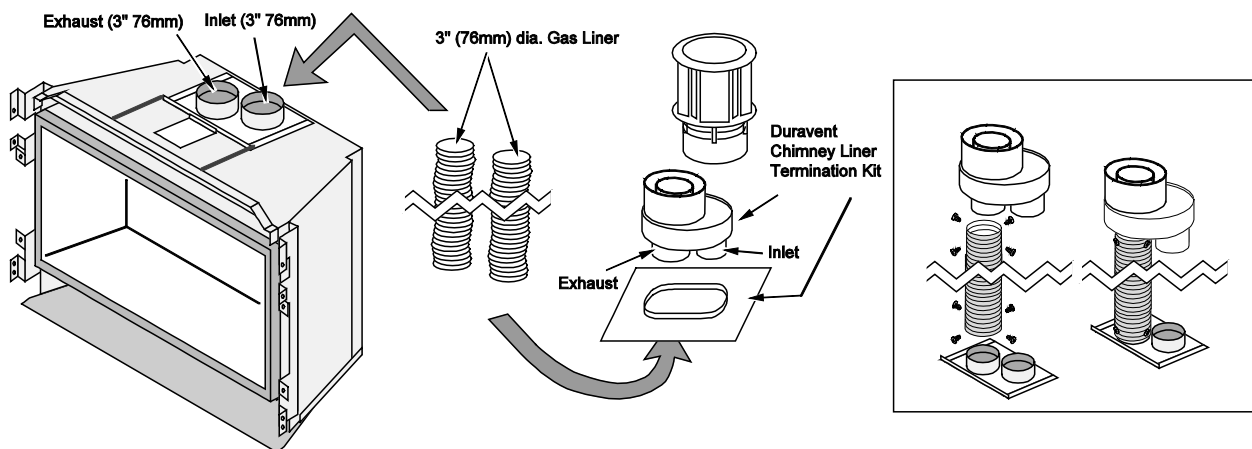

Vent Location

- A vent restrictor is built into the appliance to adjust the flow rate of exhaust gases. This ensures proper combustion for all vent configurations. Depending upon the vent configuration, you may be required to adjust the restrictor position.
- NOTE:** The vent location changes based upon restrictor position. Position # 1 is shown below. Each restrictor position moves the vent location forward (toward the fireplace opening) approximately $\frac{1}{4}$ " (7mm).

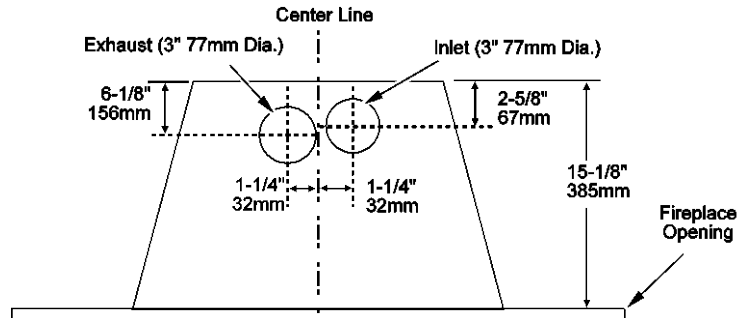

Vent Configurations

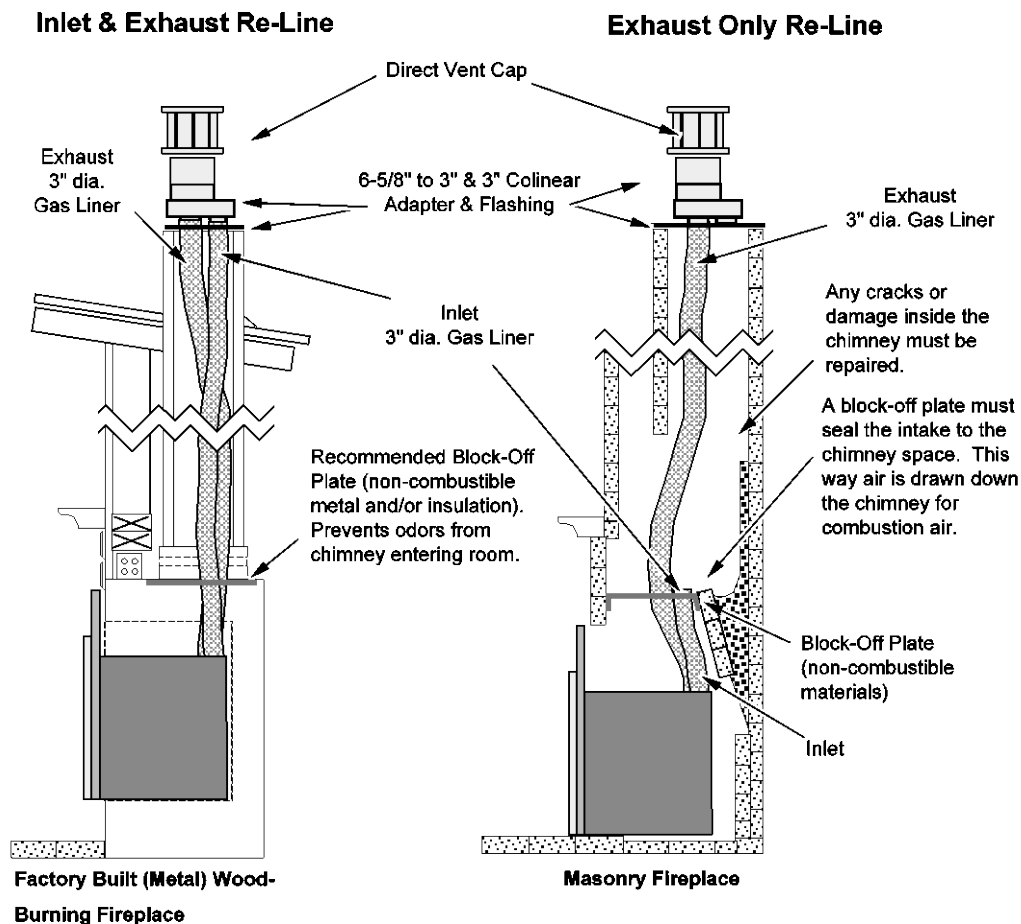

NOTE: You may use either re-line configuration with a masonry or zero-clearance fireplace.

CAUTION: The "Exhaust Only Re-line" is not covered under the appliance safety standard (ANSI Z21.88 CSA 2.33) used in the safety certification of this appliance. The Intertek safety certification does not apply to this installation. Before installing the appliance using this method, contact the Authority Having Jurisdiction to determine if this installation is acceptable in your area. This type of installation requires a minimum chimney cross section of 48 square inches.

Vent Connector Removal and Installation

- The vent connector is shipped attached to the insert, but may be removed to facilitate tight installations. See the directions below for installation.
1. Route the flex vent through the chimney from above (leave an extra 3' at the top). Make sure the flex is thoroughly stretched.
 2. Remove the vent connector and attach it to the flex vent (see the instructions on the following page).
NOTE: be careful of the anti-seize on the connector – it will stain clothing, etc.
 3. Pull on the flex vent until the vent connector is at the same height as the insert. Temporarily attach the flex vent to the top of the chimney (leave extra slack).
 4. Slide the insert into place, guiding the vent connector into the guides on top of the insert.
 5. Attach the vent connector to the appliance (see the following page for details).
 6. Remove any excess slack in the flex line and attach the vent termination.

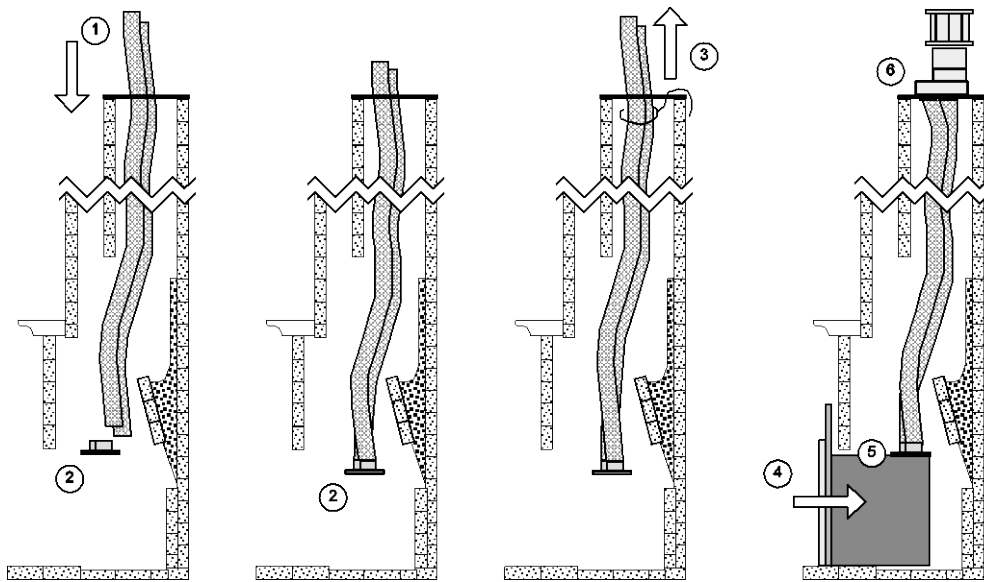

Vent Connector Removal and Installation (continued)

Vent Connector Removal

Pull the vent connector rod forward.

WARNING: The anti-seize on the vent connector can stain clothing, carpets, or other items.

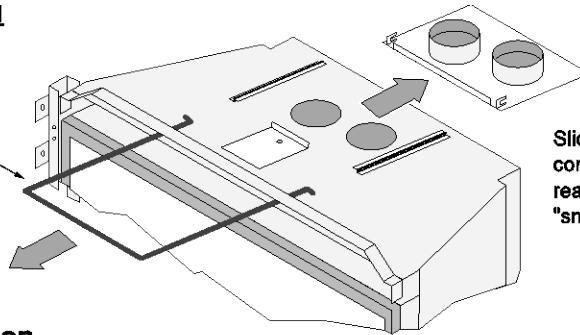

Slide the connector to the rear. It will "snap" out.

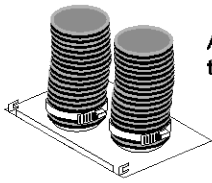
Vent Connector Installation

Attach the flex vent to the vent connector.

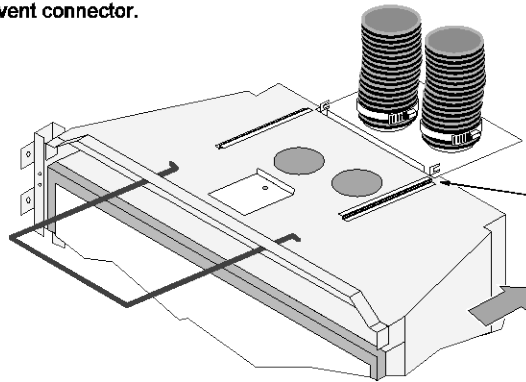

Slide the insert into place, lining up these guides with the edges of the vent connector.

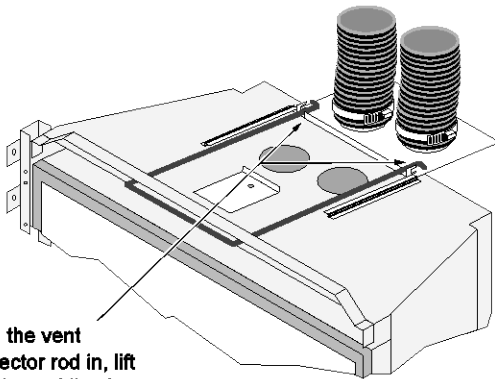

Push the vent connector rod in, lift slightly, and line it up so the tabs on the end of the rod engage the hooks on the vent connector

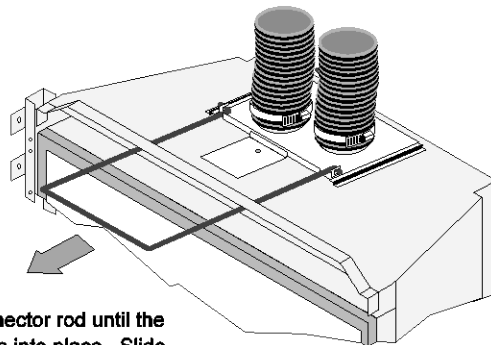

Pull on the vent connector rod until the vent connector snaps into place. Slide the vent connector rod in to conceal it.

Surround Panel Installation

NOTE: The insert may be installed without surround panels.

3-Piece Surround Panels

PANEL SIZE	WIDTH	HEIGHT	PART #
8" x 10" Rectangular	40-3/8" 1026mm	28-7/8" 734mm	96100301
Arched (8" x 10")	40-3/8" 1026mm	28-7/8" 734mm	98500605
10" x 13" Rectangular	44-3/8" 1128mm	31-7/8" 810mm	96100302
4" x 6" Rectangular	37-1/8" 943mm	25" 635mm	96100300

1 Follow the directions to the right to install the side panels.

2 Follow the directions below to install the top panel.

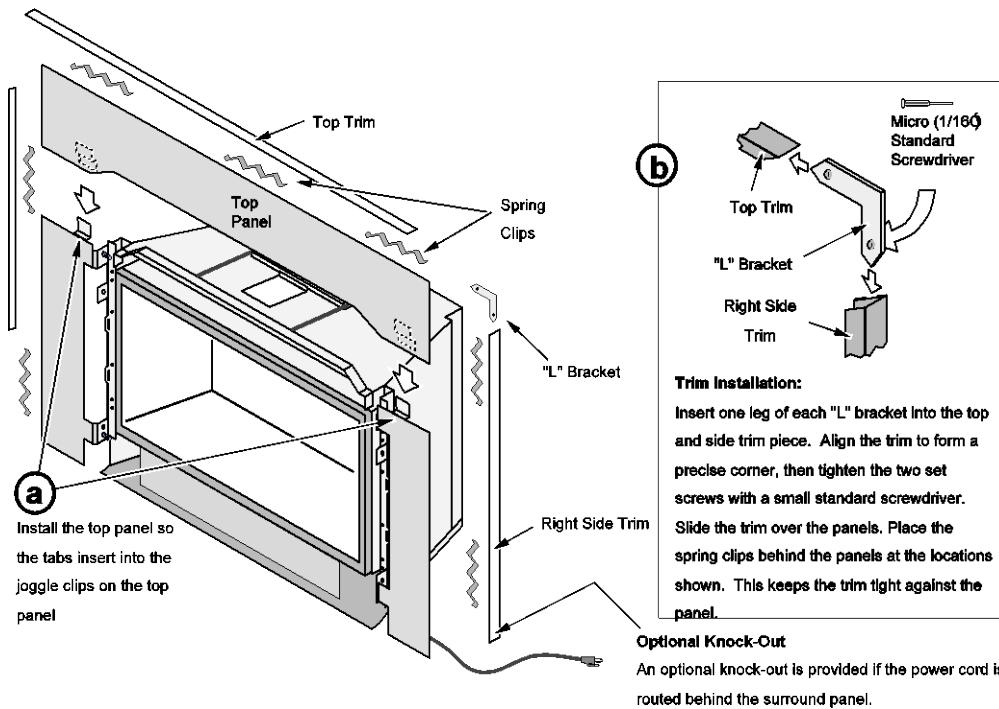
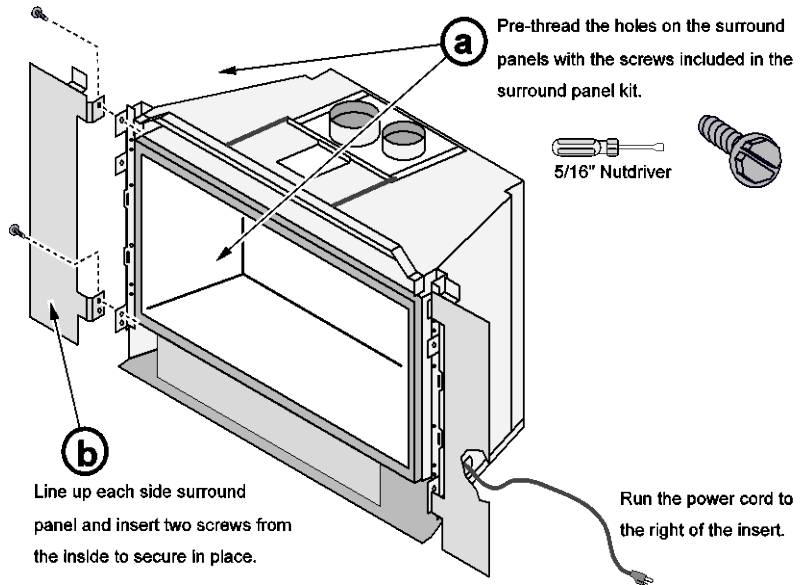

COVER PLUGS FOR ON/OFF SWITCH AND RHEOSTAT

Install the button plug and switch plug into the surround panel trim to conceal the mounting holes (see the illustration below).

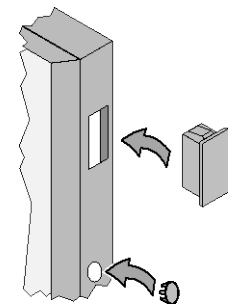

1-Piece Surround Panel

- DVS – 25" by 38" (635mm by 966mm) 96100318
- DVS – 28-1/2" by 40" (724mm by 1016mm) 96100324

NOTE: The panels may be cut down in size and placed within the fireplace opening.

Routing the Power Cord

Because this panel fits flush against the fireplace facing, the panel does not have a notch allowing the power cord to exit the fireplace. We recommend using the insert wiring kit (sku 97200315) to route power to the insert. Otherwise, route the power cord behind the panel to the right side (the panel or fireplace may be notched, if required).

Installation

1. Attach the mounting brackets as shown below.

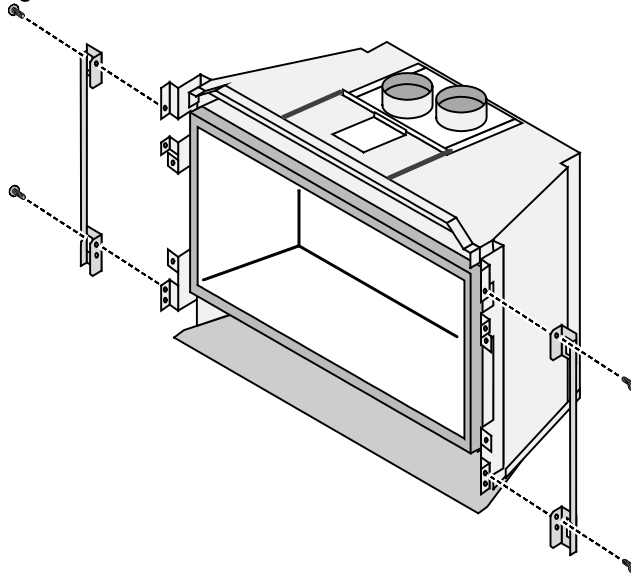

2. Attach the surround panel as shown below.

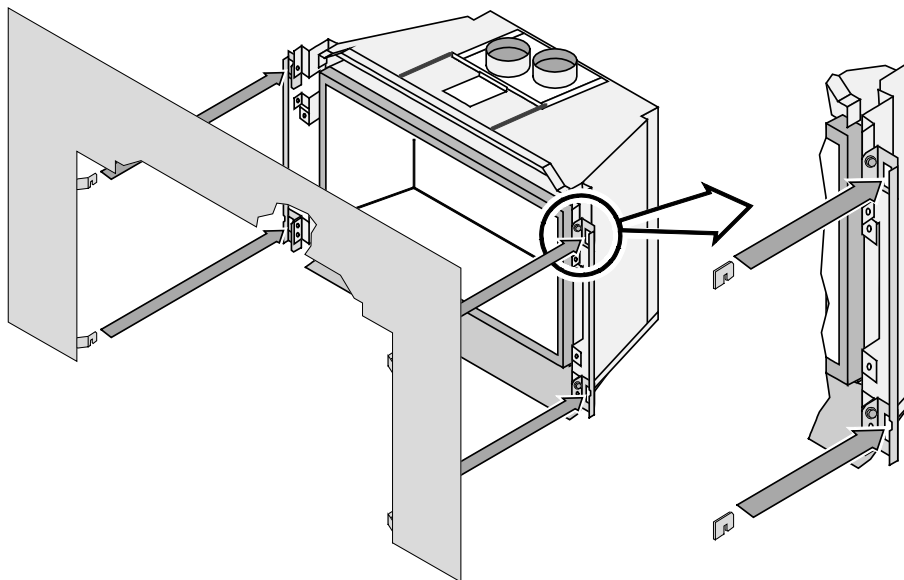

Glass Frame Removal and Installation

- Warning:** The appliance must be completely cool before removing the glass.
- Warning:** Do not strike or slam the glass.

- a** Open the four latches holding the glass frame in place (start with the two below the glass) - follow the directions shown to the right.

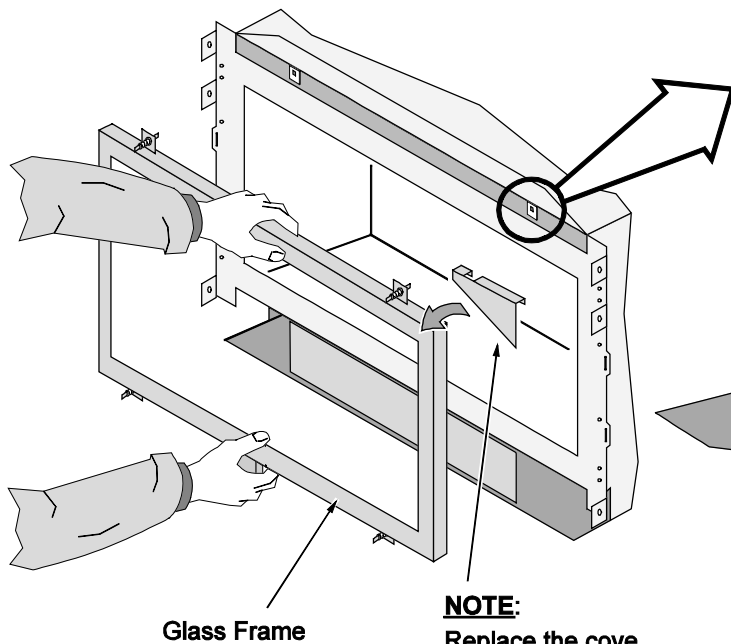

Glass Frame

NOTE:
Replace the cove covers for those faces using them.

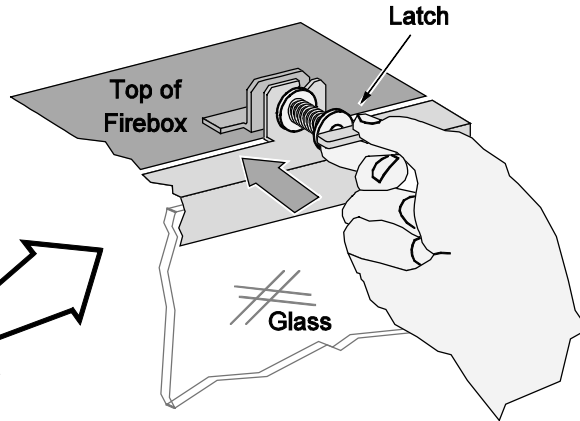

Push in on the latch.

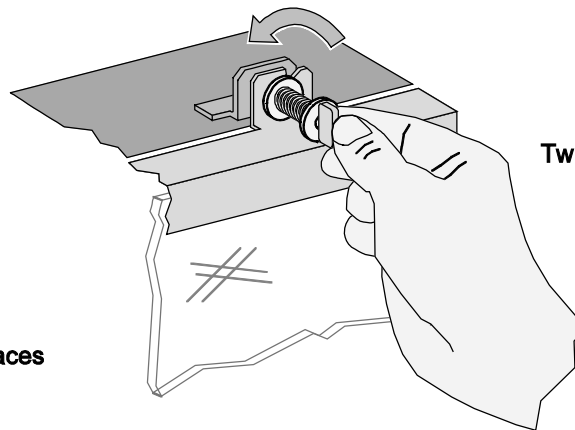

Twist 1/4 turn.

- b** Lift the glass frame up and pull it forward to remove. **NOTE:** You may need to lift the glass frame while re-attaching.

Re-Attaching the Glass Frame:

- Hang the glass frame on the firebox.
- While holding in place, attach the upper latches (follow the instructions to the right in reverse).
- Lift the glass frame slightly and attach the lower latches.

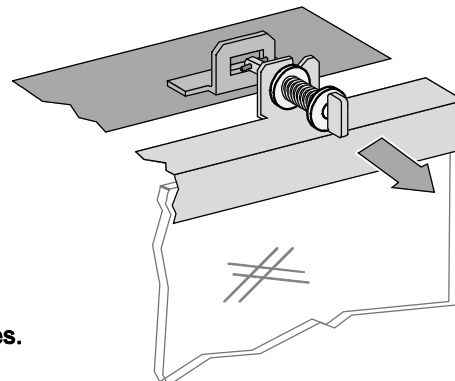

The latch will then disengage from the latch bracket.

Glass Frame Removal and Installation (continued)

The glass latch can come loose from the glass frame. This occurs when the latch is turned 1/8 turn when disengaged from the unit. Follow the directions below to re-install the latch if it comes loose.

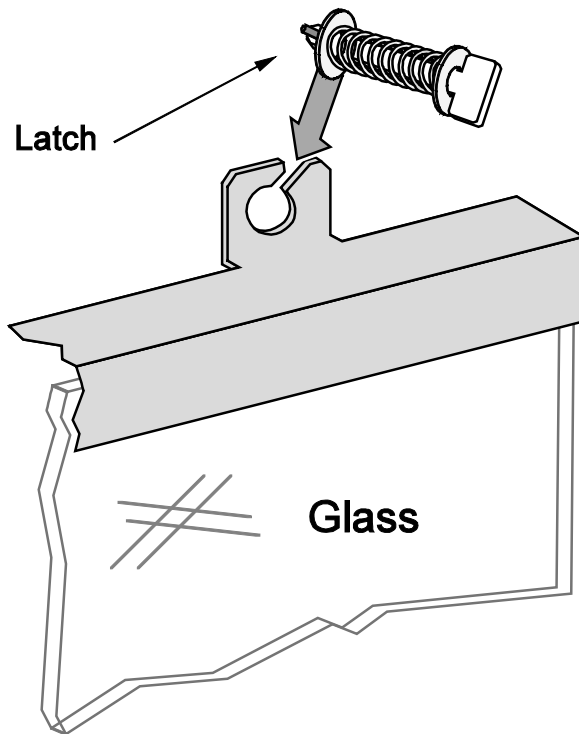

Hold the latch at an angle and insert it into the slot on the glass frame. Note how the washer fits in front of the flange on the glass frame. You will need to push slightly to get the latch to insert.

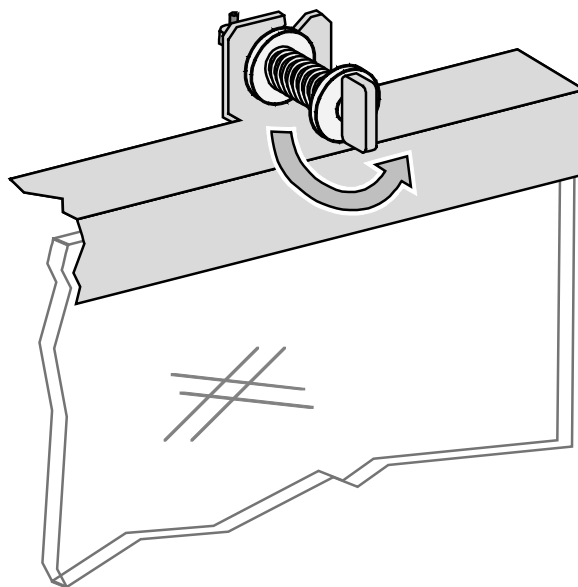

Once fully inserted, turn the latch until it is level.

Steps for Finalizing the Installation

1. Remove the glass (see page 21).

NOTE: If using propane (LP) convert the appliance prior to installing the logs.

2. We recommend you purge the gas line at this time (with the glass removed). This allows gas to be detected once it enters the firebox, ensuring gas does not build up.

3. Make sure the accent light bulb is in place and works correctly.

NOTE: Take care to not touch the bulb with your fingers – use a cloth or paper towel).

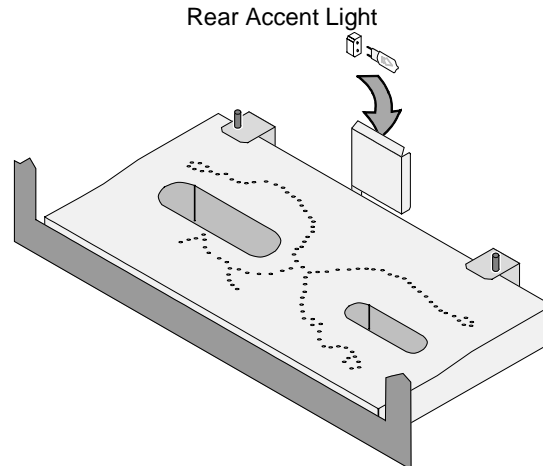

4. Install the four AA batteries (see illustration below). The AA batteries act as a power backup in case the household (AC) power goes out and are required for operation. Install three AAA batteries into the remote (see illustration below). Synchronize the transmitter to the IFC (see page 26).

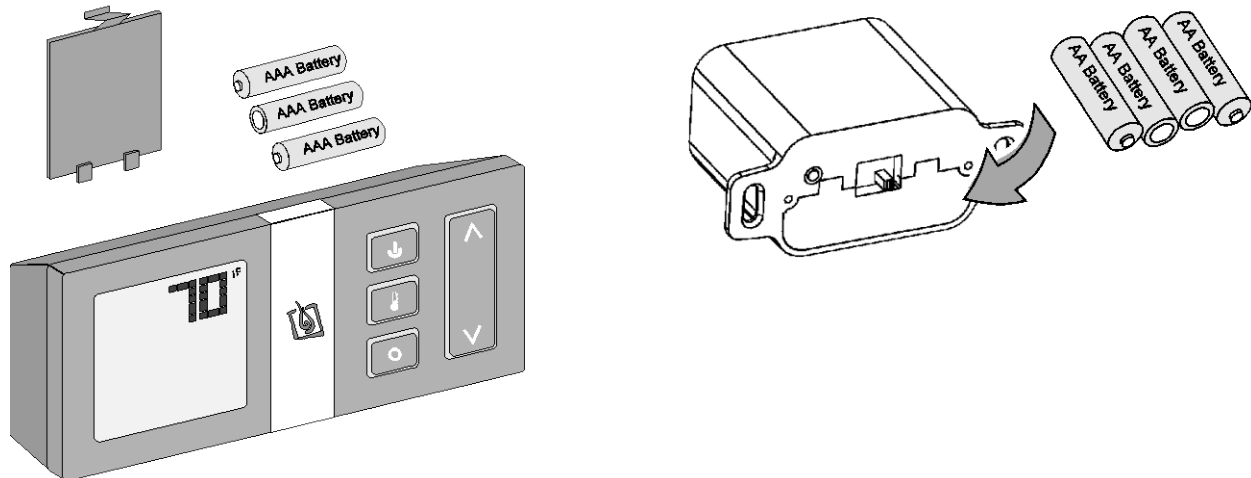

5. Install the burner and media (and firebacks if applicable).
6. Replace the glass.
7. Start the heater.

8. Leak test all gas joints.
9. Check the air shutter following the directions below.

Air Shutter Adjustment

Let the heater burn for fifteen minutes (make sure the logs and glass are in place). The flames should be yellow with no sooting. Adjust the air shutter, if necessary, to achieve the correct looking flame.

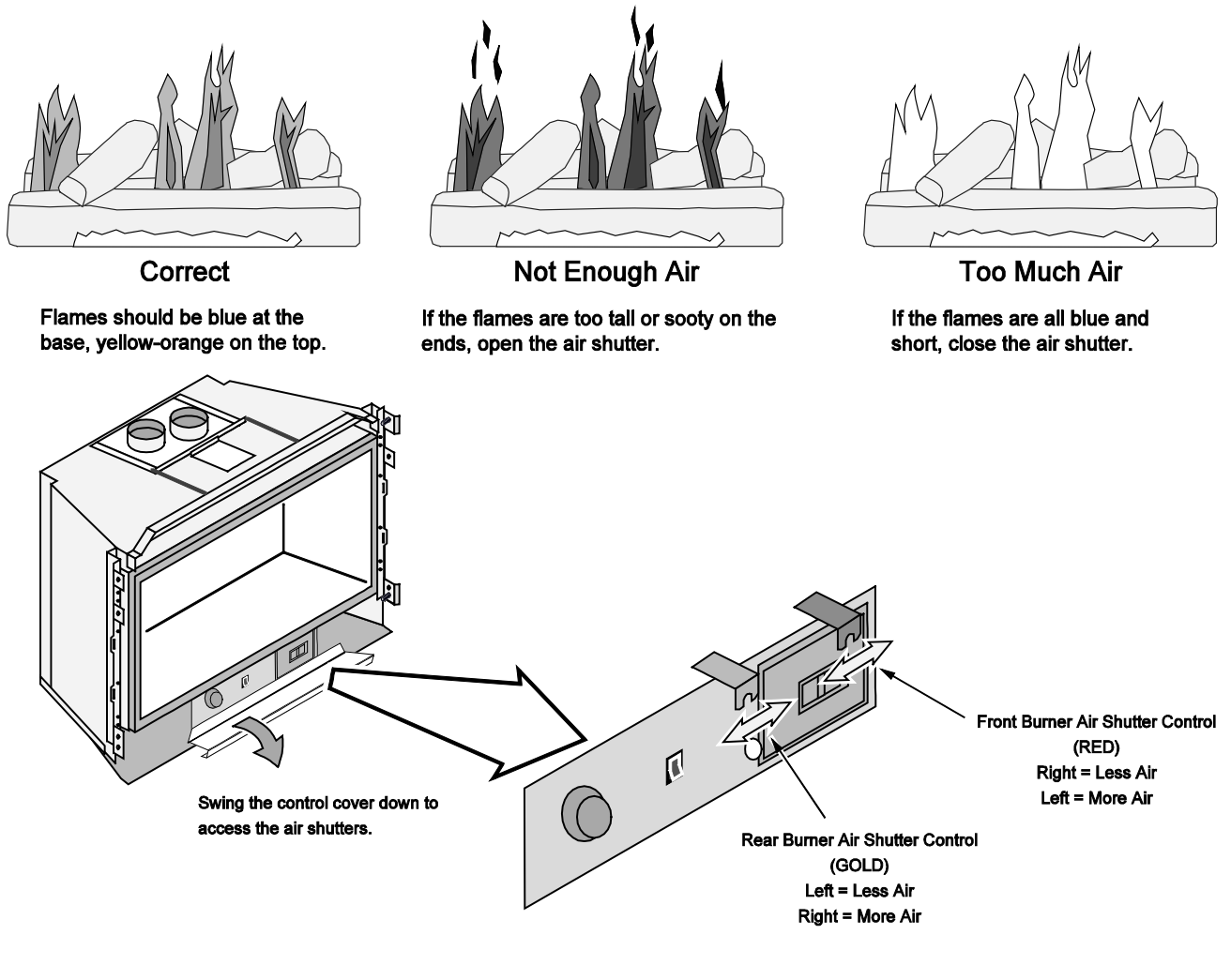

10. Attach the face following the directions included with the face.
11. Adjust the flame to its highest position - the flames should not contact the top of the firebox. Check the flame on low position. The flames should burn off of each burner hole. If the heater does not work correctly, contact your Travis dealer for a remedy.
12. Give this manual to the home owner for future reference and fully explain operation of this heater.

Before You Begin

- Read this entire manual before you use your new heater (especially the section "Safety Precautions" on pages 4 & 5). Failure to follow the instructions may result in property damage, bodily injury, or even death.

Remote Control Warnings

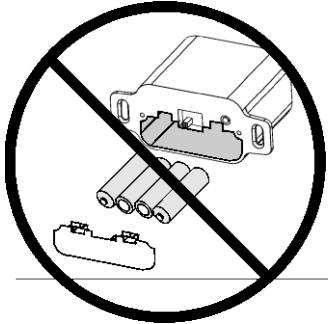

**KEEP BATTERIES AND COVER
INSTALLED AT ALL TIMES**

The remote control system requires the batteries and battery cover to remain in place at all times. Once the batteries or cover are removed, the system may re-start in standing pilot mode. If this occurs when the heater is in Remote Mode, you will not be able to turn the heater off manually from the battery box.

If you need to replace dead batteries, make sure to **turn the appliance off** before removing the batteries.

NOTE: If the batteries go dead, the system will operate normally as long as household power is present.



The transmitter and IFC are radio frequency devices. Placing the transmitter in or near metal may severely reduce the signal range.



Turn off the main gas supply to the appliance during appliance installation or maintenance.



During appliance installation or maintenance or in case of remote control malfunction turn off the main gas supply.

Remote Set-Up

Verify the Switch is on “REMOTE”

The battery holder has a switch built into it (see **Figure 1**). This switch must remain in the REMOTE position for the remote to operate.

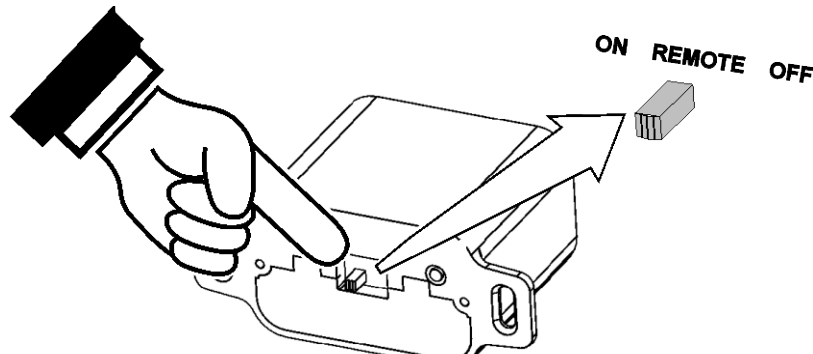

Figure 1

Synchronize the Transmitter to the IFC

The transmitter will need to be synchronized to the IFC (Integrated Fireplace Control) before the remote will work correctly. Synchronizing is done in the following two steps below (see **Figure 2**):

1. Press the PRG (Program) button on the battery box (IFC will beep 3 times).
2. Press the “ON” button on the transmitter (IFC will beep 3 times).

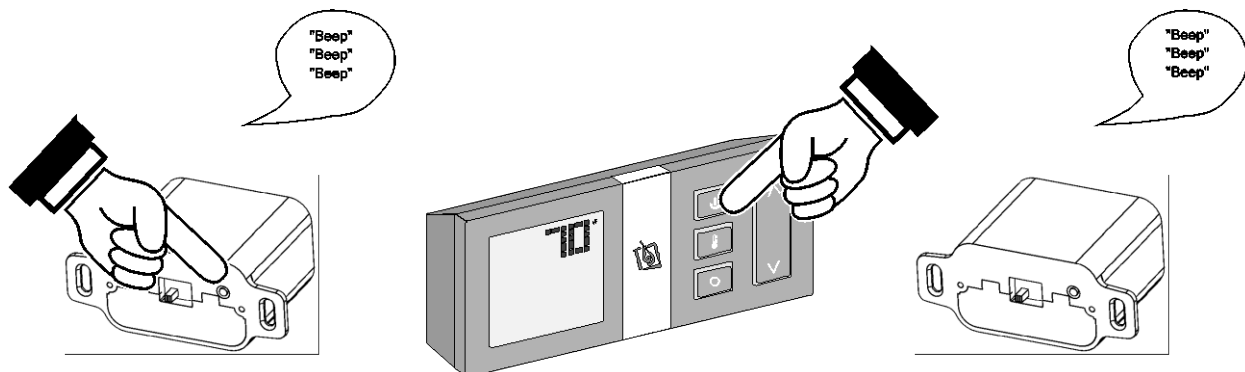

Figure 2

NOTE: If power is cut off to the IFC for an extended period of time, you may need to re-synchronize the remote.

Clearing the System Memory

This appliance uses an Integrated Fireplace Control (IFC) to store the unique code for the remote control. If you wish to clear the system memory, **MAKE SURE GAS IS TURNED OFF TO THE APPLIANCE** then press the PRG (Program) button for 10 seconds. The pilot will start to spark repeatedly, signifying all system memory has been cleared. The system will return to its original configuration: a remote will need to be synchronized; and, the system will operate under continuous pilot mode.

Location of Controls

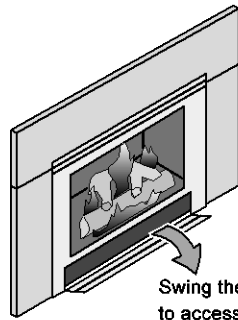

Swing the access door and control cover down to access the battery holder / switch.

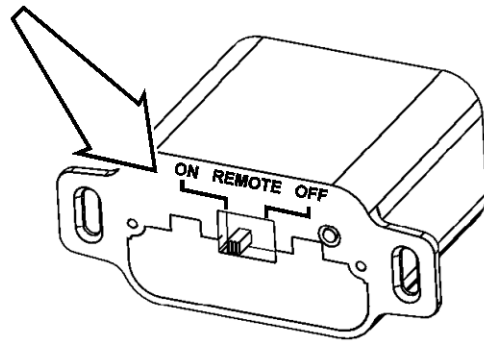

Most features will be controlled by the included remote.

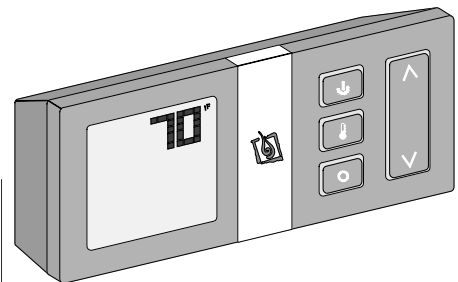

Direct Operation

The fireplace may be directly operated from the battery holder. The three positions are below (see Figure 3):

- ON** – Burner turns on (regardless of transmitter settings).
- OFF** – Burner turns off (regardless of transmitter settings).
- REMOTE** – Burner is controlled by the transmitter.

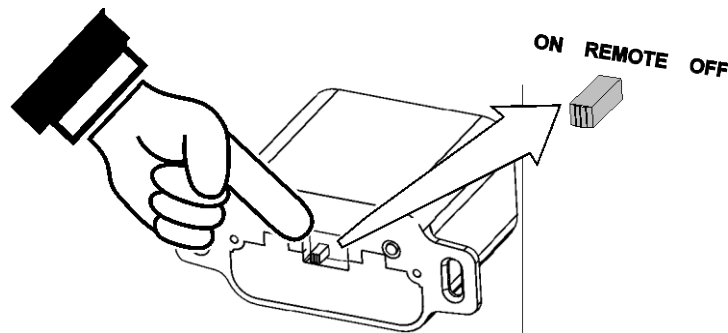

Figure 3

NOTE: When the battery holder switch is turned to ON or OFF, the mode settings (Flame Height, Comfort Control) will remain in the same state as before the switch was moved (i.e.: the IFC “remembers” the last setting). If you wish to adjust the mode settings use the transmitter mode button to adjust the settings (see “Mode Controls” on page 31). The thermostat and burner on/off operating functions will not work on the transmitter.

Starting the Fireplace for the First Time

- Burn the heater at a high setting with the blower off for an extended period (up to 48 hours). This will cure the painted surfaces. **Fumes** from the paint curing and oil burning off the steel will occur. This is normal. We recommend opening a window to vent the room.
- **Condensation** may appear on the glass each time you start the fireplace - this is normal.
- **Blue Flames** will occur on the fireplace when it first comes on. After fifteen minutes the flames will turn a more realistic yellow and orange color.
- Certain installations use a remote, thermostat, or wall switch to turn the fireplace on and off. If this is the case, leave the ON/OFF switch "ON".
- Verify the power backup batteries are installed.

Continuous/Intermittent Pilot Switch

This heater may run with the pilot continuously running or in intermittent mode. For most homeowners, the intermittent mode is preferred (this saves fuel, doesn't give off un-needed heat). However, in some situations the homeowner may prefer to switch the heater to continuous pilot. The most typical reasons for switching to continuous pilot are:

- Very Cold Conditions – in very cold conditions you may notice that the burner does not light quickly, and the flames lift off the burner. If this is situation, we recommend you switch to continuous pilot. This will create a slight draft in the vent, allowing for the burner to light quickly and draft correctly.
- Excessive Condensation on Glass After Startup – certain installations may encounter excessive fogging on the window after startup (not just the first time the heater was started). This is an aesthetic condition that may be remedied by switching the heater to continuous pilot.
- Cold Glass or Heater Front – in very cold conditions you may notice that the heater front and glass become very cold. To remedy this, switch the heater to continuous pilot.
- Frequent On / Off Operation – if you are frequently turning the heater on and off, you may wish to leave it in continuous pilot. This allows the burner to turn on more quickly, without pilot ignition delay.

Switching from Intermittent (IPI) to Continuous Pilot (CPI)

The pilot mode on this appliance is adjusted using the remote. With the remote in the off position (thermostat off, manual off), follow the directions below to adjust the pilot mode.

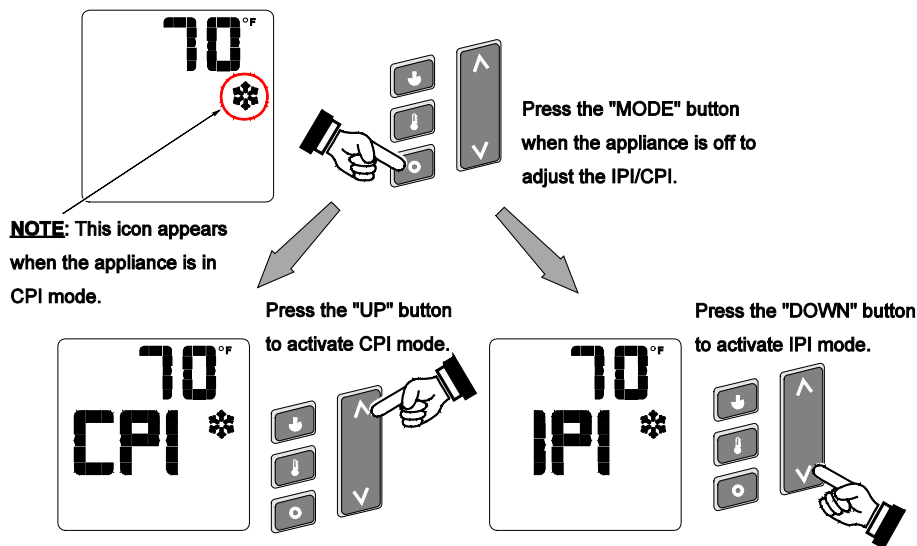

Figure 4

Remote Operation

When the switch on the battery holder is set to “REMOTE” the transmitter operates the fireplace. Once you understand how the transmitter works, you will be able to operate your fireplace quickly and easily.

Display Overview

The transmitter display has four main sections (see **Figure 5**).

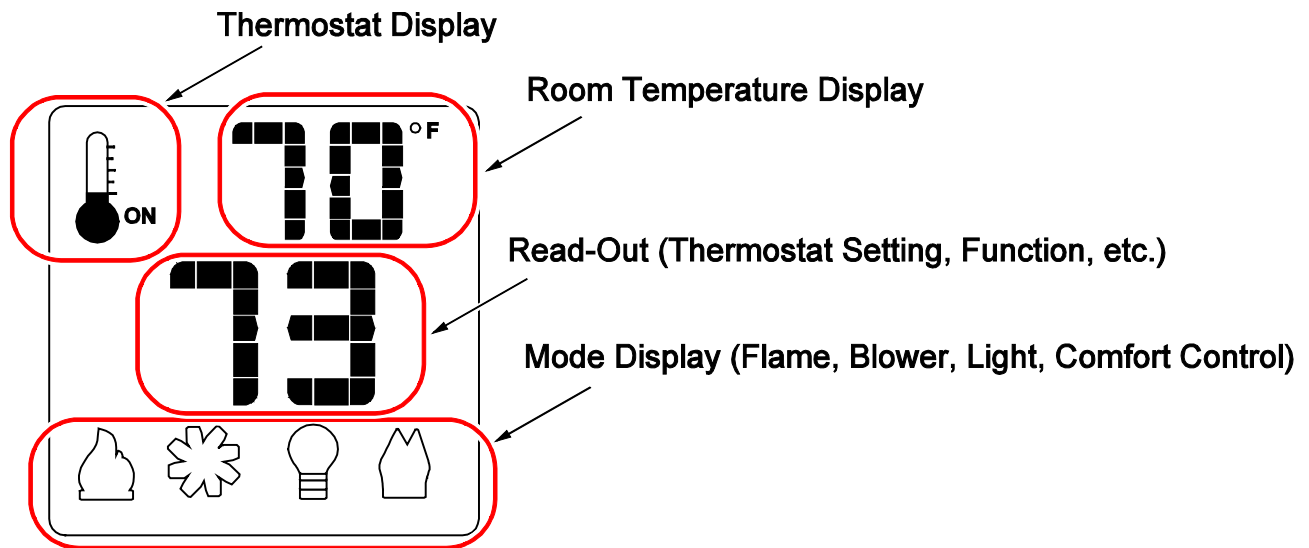

Figure 5

Listen for the “Beep”

Each time you press a button on the transmitter that controls the fireplace, a “beep” will come from the IFC. When you change thermostat target settings the IFC will not beep.

NOTE: When the batteries start to get low, the IFC will beep intermittently. When the batteries are nearly depleted, the IFC will no longer beep. See “IFC Batteries” on page 33).

Manual On-Off / Smart Thermostat / Standard Thermostat

Use the thermostat button to cycle through the three thermostat settings (see Figure 6).

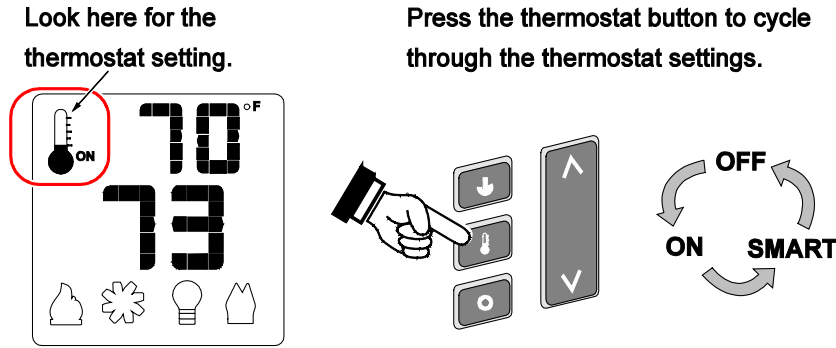

Figure 6

- **MANUAL ON/OFF** – The burner will turn on and off using the remote (see Figure 7). Press the On/Off button to control the burner. When off, the display will only show the current temperature.

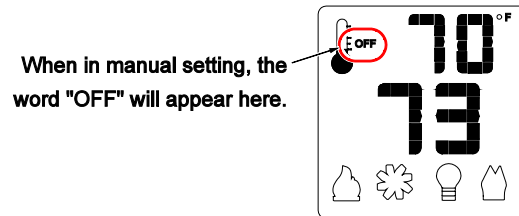

Figure 7

- **SMART THERMOSTAT** – While in smart thermostat, the transmitter will control the burner to achieve the target temperature (see Figure 8 below). Flame height will be adjusted up or down to allow operation without turning the burner on and off (also called "smart modulation"). To adjust the target temperature, press the UP and DOWN buttons until a suitable temperature is achieved.

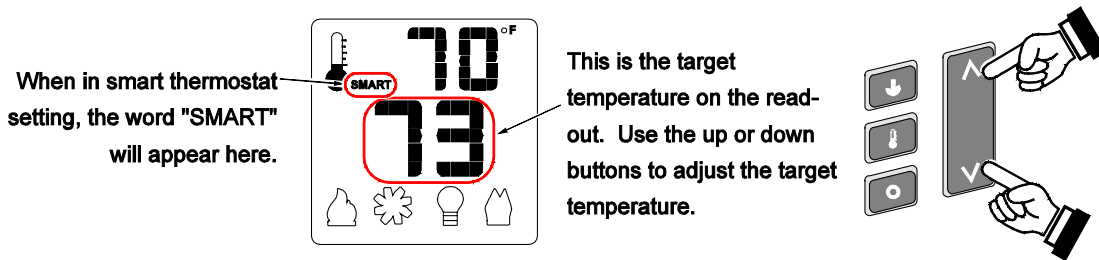

Figure 8

- **STANDARD THERMOSTAT** - While in standard thermostat setting, the transmitter will turn the burner on and off to achieve the target temperature (see Figure 9 below). To adjust the target temperature, press the up and down buttons until a suitable temperature is achieved.

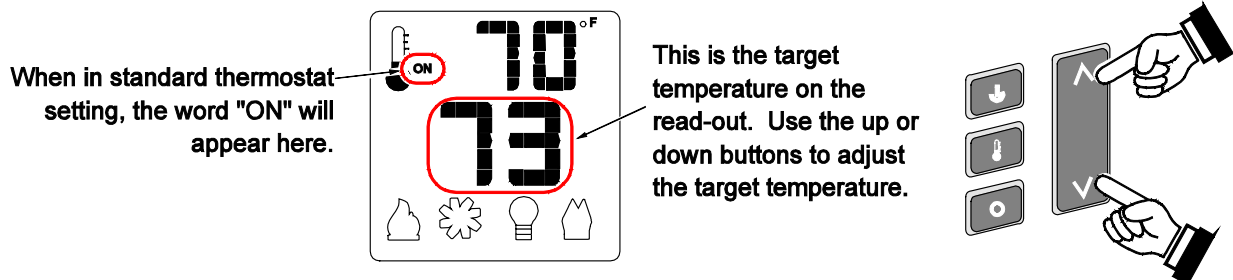

Figure 9

NOTE: If the transmitter batteries go dead while in thermostat setting (standard or smart), the appliance will shut off after approximately 24 hours.

Mode Controls (Flame, Blower, Light, Comfort Control)

Use the mode button to cycle through the four mode controls (see Figure 10 below).

Press the mode button to cycle through the mode settings.

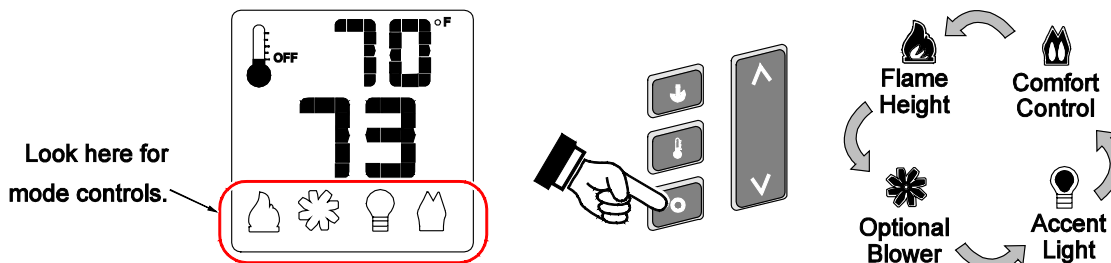

Figure 10

Flame Height

Flame height may be controlled using the UP and DOWN buttons when in Flame Height Mode (see Figure 11 below). The center display will display the 7 settings, from “OFF” to “HI” for full on.

NOTE: Flame height may not be adjusted if operating in Smart Thermostat setting.

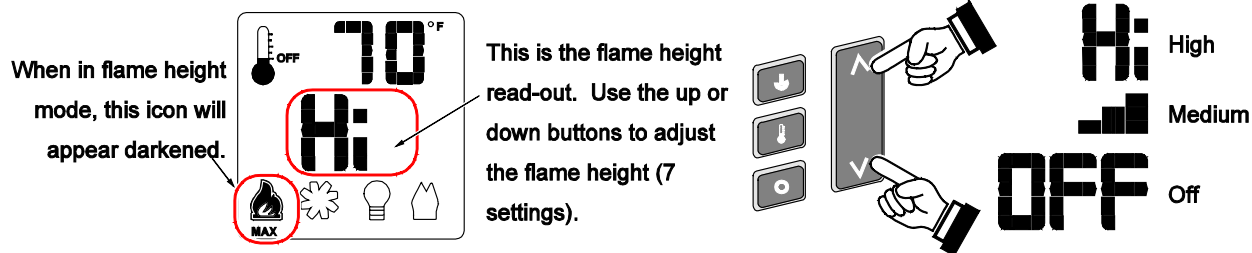

Figure 11

Blower Speed

The blower may be controlled using the up and down buttons when in Blower Speed Mode (see Figure 12). The center display will display the 7 settings, from “OFF” to “HI” for full on.

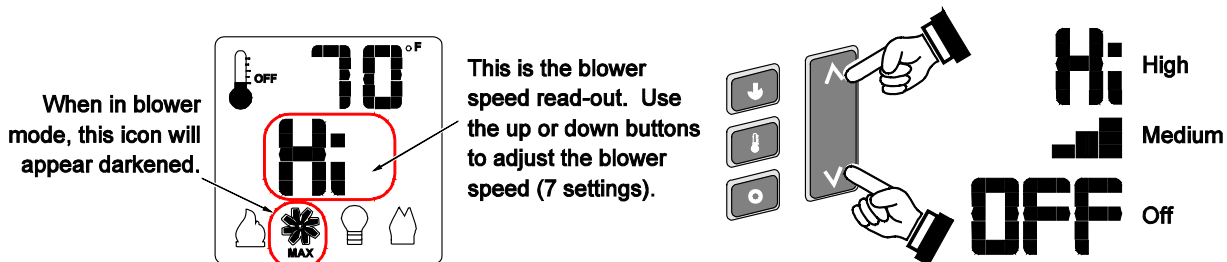

Figure 12



MANUAL MODE – BLOWER OPERATION

When in Manual Mode the blower will remain on, even if the burner is turned off and the heater cools.

Either manually turn the blower off, or turn off the heater by pressing the On/Off button.

Mode Controls - continued

Accent Light

The Accent Light (night light) inside the heater may be turned on and off using the up and down buttons when in Accent Light Mode (see Figure 13). The center display will display the 7 settings, from “OFF” to “HI” for full on.

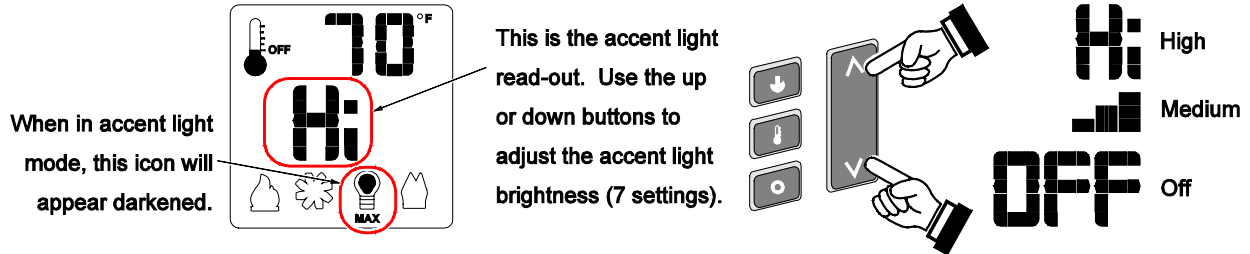

Figure 13

HINT: If you wish to leave the accent light on while turning the burner off, adjust the Flame Height to “OFF” (see above).

Comfort Control (rear burner)

The comfort control (rear burner) may be turned on and off using the up and down buttons when in Comfort Control Mode (see Figure 14). The center display will display either “ON” or “OFF”.

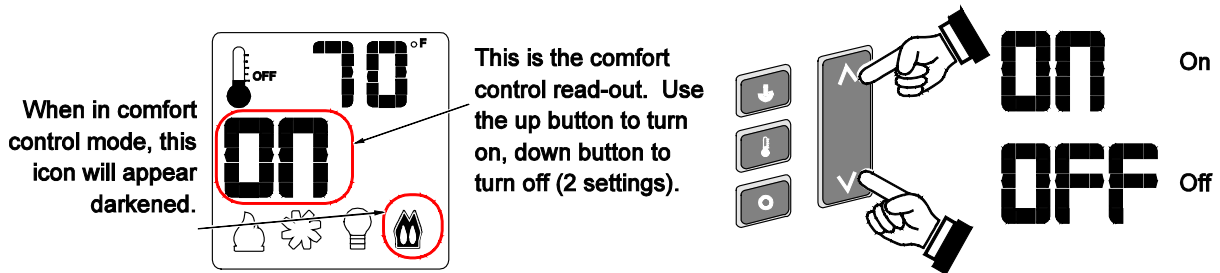

Figure 14

Display Fahrenheit or Celsius

- With the system in the “OFF” position, press both the MODE and THERMOSTAT buttons simultaneously to toggle between Fahrenheit (F) and Celsius (C).

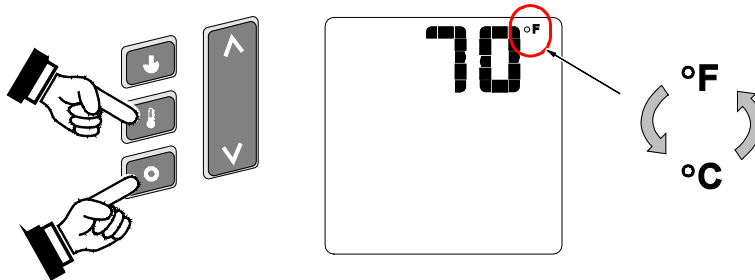

Figure 15

Low Battery Indicator

Transmitter Batteries

The transmitter has a battery-level indicator. When it indicates low battery voltage (see Figure 16 below), install three new AAA alkaline batteries into the transmitter (see “Transmitter Battery Installation” on page 33).

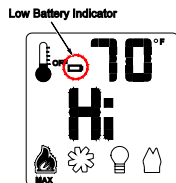

Figure 16

IFC Batteries

The IFC (Integrated Fireplace Control) will “beep” repeatedly when the batteries go low. Install four new AA alkaline batteries into the battery box when this occurs (see “Battery Installation” on page 33). In applications where the appliance is required to provide heat, we recommend replacing the batteries before each heating season.

Battery Replacement

Battery Installation

Install four AA batteries into the battery holder (see Figure 17 below). These batteries act as a power backup in case the household (AC) current goes out.

Transmitter Battery Installation

Install the three included AAA batteries into the remote.

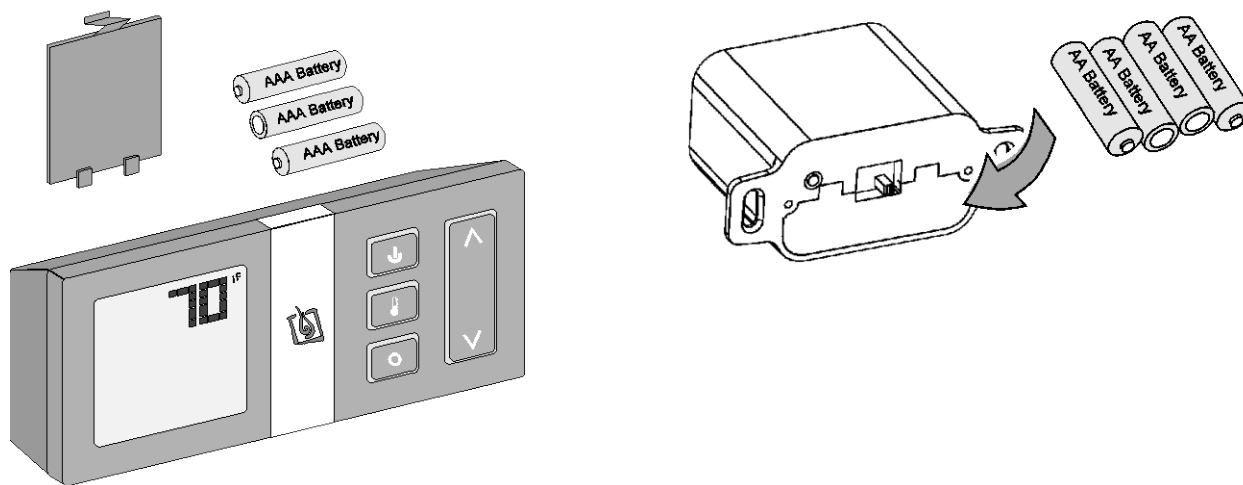

Figure 17

Power Outages

The remote will work if household current (AC power) is disconnected. The batteries inside the battery box will continue to power the heater but the accent light and blower will not operate.

Child-Proof Feature

The child proof feature disables the control buttons, preventing un-wanted use of the remote.

- Press both the MODE and UP buttons simultaneously to turn this feature on and off (see Figure 18 below).

HINT: This feature is especially useful while using the thermostat setting.

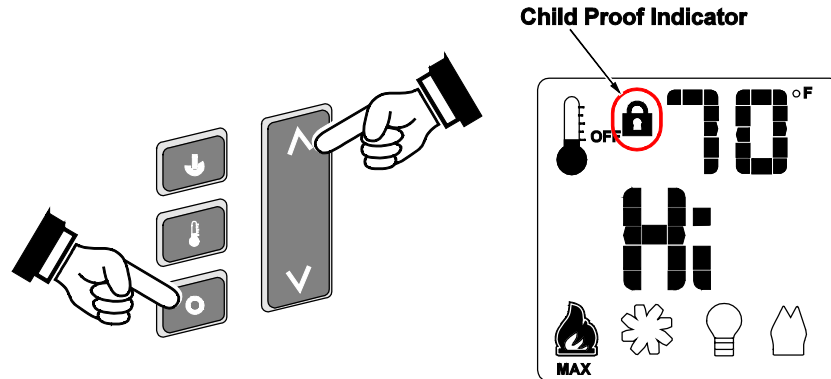
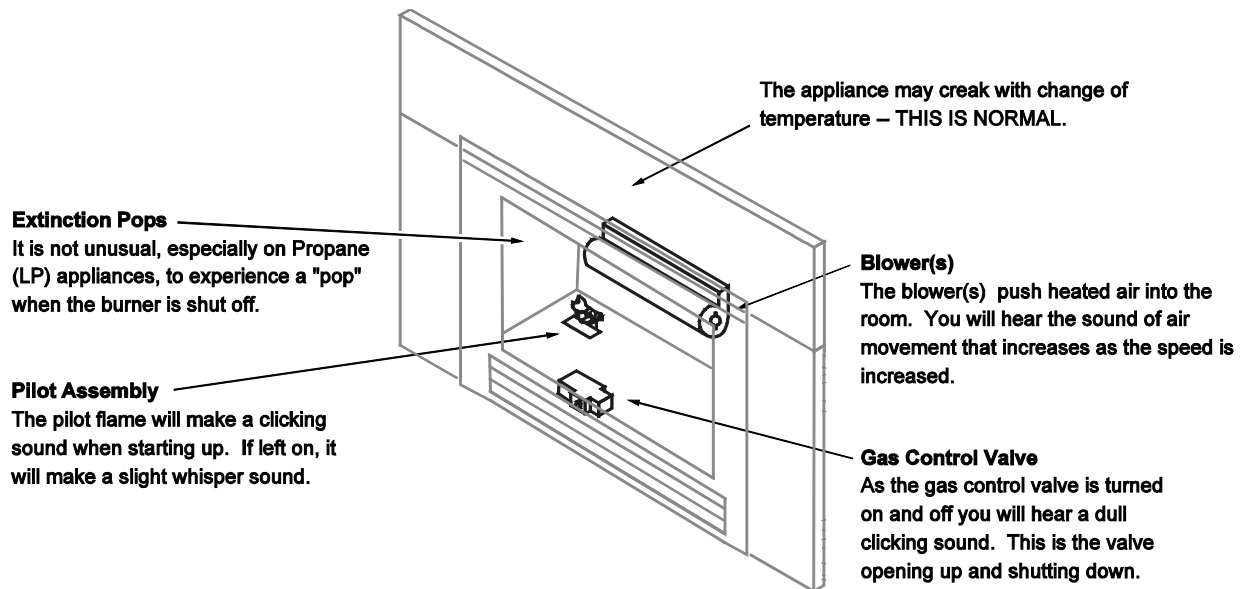

Figure 18

Normal Operating Sounds



Normal Operating Odors

This appliance has several areas that reach high temperatures. Dust or other particles on these areas may burn and create an odor. This is normal during start-up. You may notice the smell is more acute if the appliance was left idle for a long period.

Maintaining Your Heater's Appearance

Fingerprints or other marks left on the optional plated surface may become etched in place if they are not wiped clean prior to turning the heater on. Clean the plated surfaces with denatured alcohol and a soft cloth (with the heater cool). Other cleaners may leave a film that may become etched into the surface.

Accent Light Replacement

The accent light in your heater provides additional lighting. The bulbs will burn out over time. To replace, follow the directions below:

- Shut off gas to the heater and let it cool for 15 minutes.
- Remove the glass (see page 21) and media.
- Replace the halogen bulbs with the following bulbs:
NOTE: Take care to not touch the bulbs with your fingers – use foam packing or a paper towel to handle the bulbs:



35 Watt 240 Volt T4 Halogen Bulb (G6.35 Base)

Lower Accent Light

The lower accent light is located at the back of the firebox behind the light deflector, as shown below. It can be removed by pulling it out.

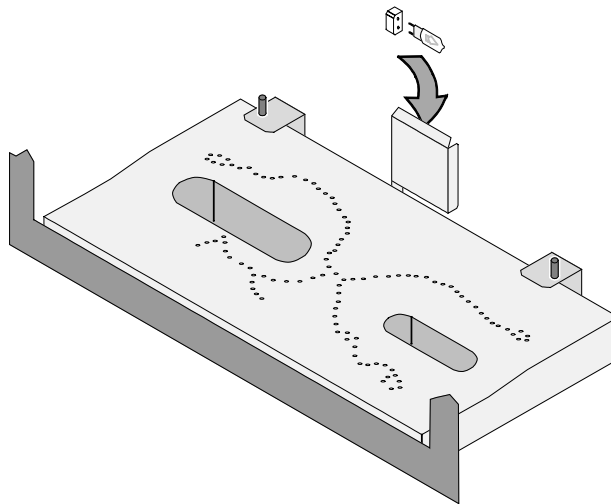

Yearly Service Procedure

- Failure to inspect and maintain the heater may lead to improper combustion and a potentially dangerous situation. We recommend the following procedures be done by a qualified technician.
1. Turn the pilot flame to continuous. It should touch approximately 3/8" of the top of the flame sensor. If it does not, contact your dealer for service.
 2. Shut off gas to the heater and let it cool for 15 minutes. Remove the glass (see page 21). Glass may be cleaned with glass cleaner and a soft cloth (do not use abrasive cleaners).
 3. Remove the media (**NOTE: the logs are very fragile**). If severely deteriorated, replace. Check the logs for sooting. A small amount of soot along the bottom of the logs is normal. If excessive sooting is found, the heater will require adjustment. Contact your dealer.
 4. Inspect the burner and remove any debris.
 - Make sure the burner is not warped, cracked, or damaged.
 - Check the firebox and area around the pilot to make sure there is no warping or damage.
 - If any problem is found, discontinue use and contact your dealer for service.
 5. Replace the media. Clean and replace the glass. If the glass is damaged, replace. Make sure the gasket along the perimeter of the glass contacts the face of the firebox and forms an air-tight seal. If it does not, re-align or replace the gasket to insure an air-tight seal.
 6. Inspect the area behind the access door. Clean if necessary. Check the gas control valve and the gas lines. If damage is found, discontinue use and contact your dealer for service. Clean the air channels, ducts, and blower.
 7. Start the main burner. Inspect the main burner and pilot flame. After 15 minutes the flames should be orange/yellow and not touch the top of the firebox. If the pilot or main burners do not burn correctly, contact your dealer for service. Monitor blower operation.
 8. Remove any debris or vegetation near the vent termination. Contact your dealer if any sooting or deterioration is found near the vent termination. Venting system should be examined by a qualified agency.

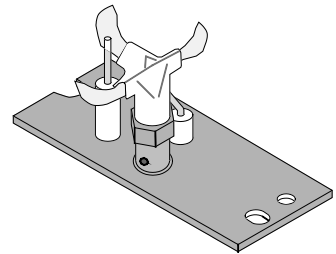

Troubleshooting Table

Problem:	Possible Cause:	Don't Call for Service Until You:
Main Burners Will Not Start	The battery box switch is turned to "OFF"..... The remote control is not working correctly..... The thermostat is disconnected or set too low..... No Propane in Tank.....	Use the switch on the battery box See the remote control instructions See "Thermostat Operation" Check Tank Level
Appliance Beeps	The power backup batteries are dead (heater will beep once repeatedly)..... The heater encountered an error when trying to start (heater beeps 3 times repeatedly) The heater encountered a pilot error (heater beeps 2 times repeatedly)	Replace the batteries (see page 33) Make sure gas is turned on. Turn heater off for 5 seconds (make sure standing pilot is off) – then turn back on. Contact your dealer if this occurs.
Thermostat Does Not Work	The battery box switch is turned to "OFF" or "ON". The thermostat is set too low.....	Turn the battery box switch to "REMOTE" Check thermostat
Blower Does Not Work	The fireplace is not getting electricity..... The fireplace is not up to temperature The blower fuse may be blown.....	Check the breaker switch Let the fireplace burn for 10 minutes Replace the fuse. See fuse location below.
Flames Are Too Blue	The fireplace has just been started..... Improper air shutter adjustment.....	This is normal - see "Starting the Fireplace for the First Time" Adjust Air Shutter - contact your dealer
Flames Are Too Short (Under 6")	The flame height may be turned too low.....	Turn the flame height to "HI" - See "Adjusting the Flame Height"
Thin Layer of Soot Covers the Glass	The logs or coals are placed incorrectly..... Improper air shutter adjustment.....	See "Log Set Installation" Adjust Air Shutter - contact your dealer
Accent Light Does Not Work	The bulb may be burned out. The accent light fuse may be blown.....	See "Accent Light Replacement" on page 35 Replace the fuse. See fuse location below.

Location of fuses (2.5 amp):

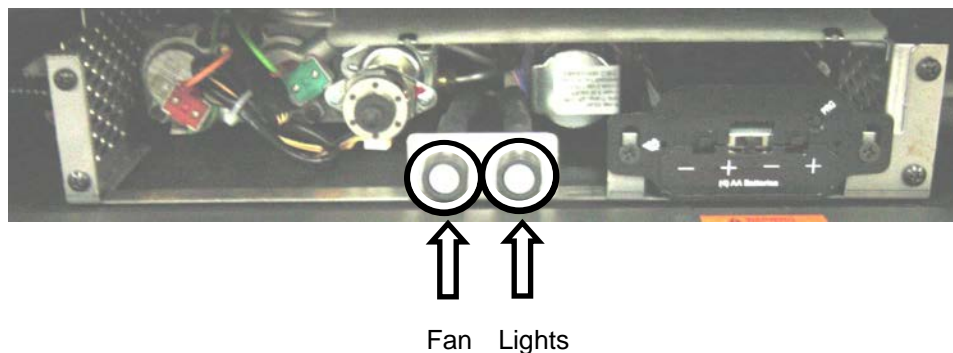

Wiring Diagram

Caution: Label all wires prior to disconnection when servicing controls. Wiring errors can cause improper and dangerous operation.

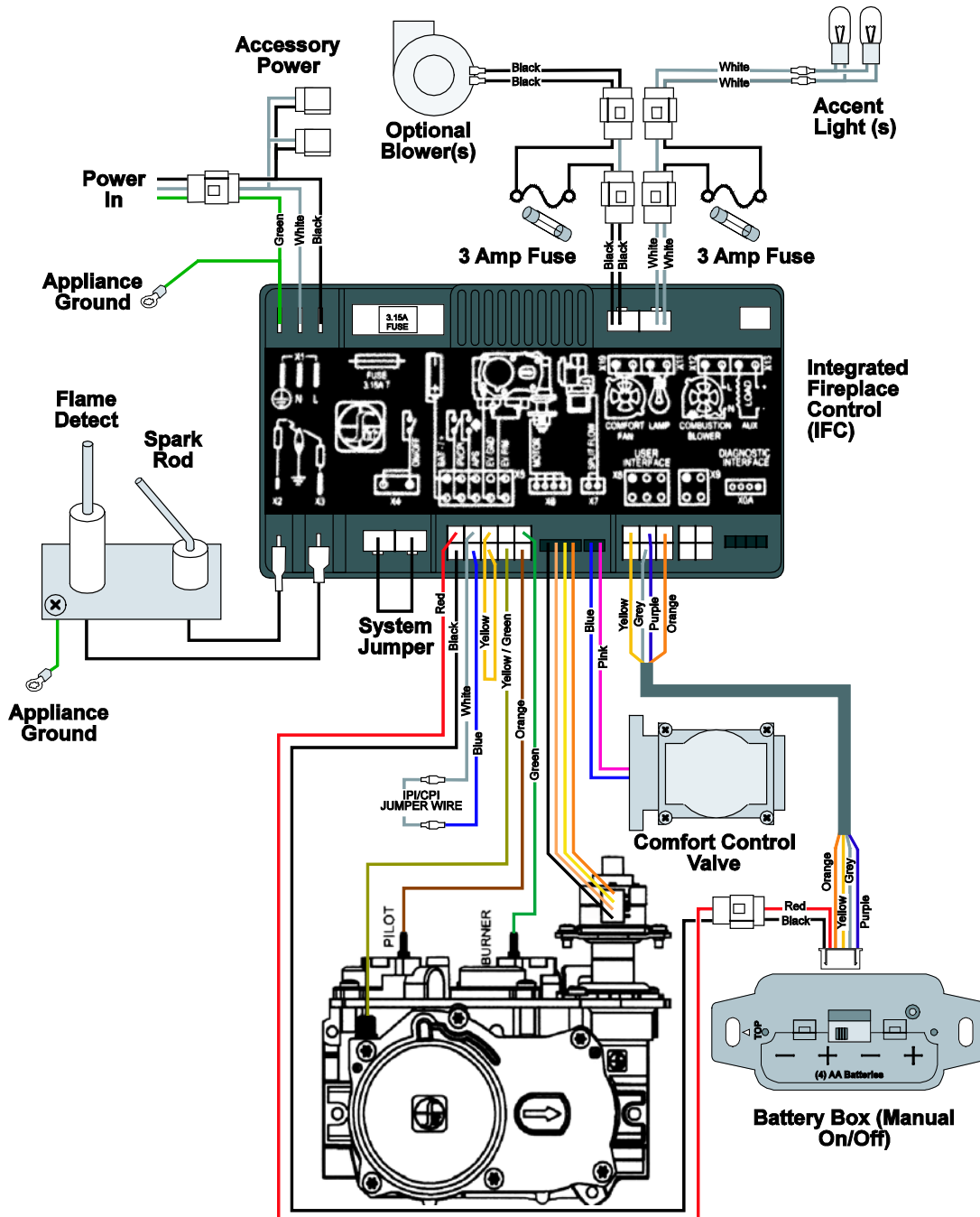

Replacement Parts List

Caution: Use only Travis Industries replacement parts. Do not use substitute materials.

Warning: Do not operate appliance with the glass front removed, cracked, or broken. Replacement of the glass should be done by a licensed or qualified service person.

Contact your local Travis Industries Dealer for a Replacement Parts List

Safety Label

The safety (listing) label is attached to the operating tag (chained to the heater near the gas control valve). A copy is shown below

DVS GSR2 Insert (Au)
Vented Gas Fireplace Heater



Minimum Clearances to Combustibles

Side of insert to adjacent wall	114 mm	See owner's manual
Hearth extension in front	0 mm	See owner's manual
Hearth extension to sides of insert	0 mm	See owner's Manual

FAN TYPE VENTED CIRCULATOR
Blower Electrical Rating: 240V, 1.5 Amps, 50 Hz, 150 Watts

Input Rate on "HI" (MJ/h)	LP	NG							
	32.7	32.7		2.74	1.13		2.74	1.13	N.G.
Input Rate on "LO" (MJ/h)	10.0	11.3		3.24	1.74		2.74	1.74	.87
Orifice Size - Front (DMS)	#58	#60		2.74	.87		2.74	.87	.87
Orifice Size - Rear (DMS)	#56	#47		.87	.87		.87	.87	.87

This appliance is equipped for installation 0-610 m. For altitudes above 600m, the vent configuration, orifice, or combination of both may need to be changed. See owner's manual for information on making these changes.

Tested to the combustion performance and construction requirements of AS 4553:2008 Gas Space Heating Appliances. This appliance must be installed in accordance with all local codes.

This DVS GSR2 insert appliance is equipped from the factory only for use with Natural Gas and is only for use with the type of gas indicated on the rating plate. For conversion to LP (Propane) use a certified kit supplied by the manufacturer. See owner's manual for information on making these changes.

This appliance may be installed in an aftermarket, permanently located, manufactured (mobile) home where not prohibited by local codes.

This vented gas fireplace heater is not for use with air filters. This appliance must be properly connected to a venting system in accordance with the manufacturer's installation instructions. Use only approved co-linear direct vent systems to vent this appliance to the exterior. See owner's manual for approved brands of venting.

WARNING: Improper installation, adjustment, alteration, service or maintenance can cause injury or property damage. Refer to the owner's information manual provided with this appliance. For assistance or additional information consult a qualified installer, service agency or the gas supplier.

This appliance is a Vented Gas Fireplace Heater. Not for use with Solid Fuel.

Young children should be carefully supervised at all times when they are in the same room as the appliance.

MANUFACTURE DATE:

<input type="checkbox"/> 2014	<input type="checkbox"/> Jan.	<input type="checkbox"/> Apr.	<input type="checkbox"/> Jul.	<input type="checkbox"/> Oct.
<input type="checkbox"/> 2015	<input type="checkbox"/> Feb.	<input type="checkbox"/> May	<input type="checkbox"/> Aug.	<input type="checkbox"/> Nov.
<input type="checkbox"/> 2016	<input type="checkbox"/> Mar.	<input type="checkbox"/> Jun.	<input type="checkbox"/> Sep.	<input type="checkbox"/> Dec.

www.lopi.com.au

Manufactured by:



TRAVIS INDUSTRIES
HOUSE OF FIRE
4800 Harbour Pointe Blvd. SW
Mukilton, VA 98275

Certificate Holder:

Dragon Wholesaling Pty. Ltd.
Unit 4, 18 Levington Drive
Bala Vista NSW 2153
Australia

0879

Register your **Dragon Wholesaling** Limited 7 Year Warranty online at lopi.com.au or complete the enclosed Warranty card and mail it within **ten (10)** days of the appliance purchase date to: Dragon Wholesaling Pty. Ltd. Unit 4, 16 Lexington Drive Bella Vista NSW 2153 Australia. **Dragon Wholesaling** warrants this gas appliance (appliance is defined as the equipment manufactured by Travis Industries, Inc.) to be defect-free in material and workmanship to the original purchaser from the date of purchase as follows:

Check with your dealer in advance for any costs to you when arranging a warranty call.
Mileage or service charges are not covered by this warranty. This charge can vary from store to store.

Component	Years 1 & 2 Parts & Labor	Years 3 Through 5 Parts & Labor	Years 6 & 7 Parts Only
Burner Assembly Burner Pan Assembly, Air Shutter Assembly, Main Burner Orifice	✓		
Electrical Assembly (within heater structure): Wiring harness, snap discs, rheostat speed control, blowers, etc.	✓		
Gas Control Assembly Adjustable control valve, fireplace controller, pilot assembly and pilot wiring	✓		
Glass Glass (breakage from thermal shock)	✓		
Media Log Set, Embers, Stones, Crushed Glass	✓		
Gold, Nickel & Copper Plating Face & Door (see "Conditions and Exclusions" # 9)	✓		
Accessories Firebacks, Power Heat Ducts, Andirons, etc...	✓		
One-Way Freight Allowance One-way freight allowance on pre-authorized repair done at factory is covered.	✓	✓	
Convection Heat Exchanger Convection heat exchanger assembly	✓	✓	
Firebox Assembly Adjustable Air Restrictor, Pressure Relief Mechanisms, Glass Attachment Mechanism	✓	✓	✓

EXCLUDED COMPONENTS:

Paint, Gasketing, and Accent Light Bulbs

CONDITIONS & EXCLUSIONS

- This new gas appliance must be installed by a qualified gas appliance technician. It must be installed, operated, and maintained at all times in accordance with the instructions in the Owner's Manual. Any alteration, willful abuse, accident, neglect, or misuse of the product shall nullify this warranty.
- This warranty is nontransferable, and is made to the ORIGINAL purchaser, provided that the purchase was made through an authorized DRAGON WHOLESALING dealer.
- Discoloration and some minor expansion, contraction, or movement of certain parts and resulting noise, is normal and not a defect and, therefore, not covered under warranty. The installer must ensure the appliance is burning as per the rating tag at the time of installation. Over-firing (operation above the listed BTU rate) of this appliance can cause serious damage and will nullify this warranty.
- The warranty, as outlined within this document, does not apply to the chimney components or other Non-Travis accessories used in conjunction with the installation of this product. If in doubt as to the extent of this warranty, contact your authorized DRAGON WHOLESALING retailer before installation.
- Dragon Wholesaling will not be responsible for inadequate performance caused by environmental conditions such as nearby trees, buildings, roof tops, wind, hills or mountains or negative pressure or other influences from mechanical systems such as furnaces, fans, clothes dryers, etc.
- This Warranty is void if:
 - The unit has been operated in atmospheres contaminated by chlorine, fluorine or other damaging chemicals.
 - The unit is subject to submersion in water or prolonged periods of dampness or condensation.
- Exclusions to this 7 Year Warranty include: injury, loss of use, damage, failure to function due to accident, negligence, misuse, improper installation, alteration or adjustment of the manufacturer's settings of components, lack of proper and regular maintenance, damage incurred while the appliance is in transit, alteration, or act of God.
- This 7 Year warranty excludes damage caused by normal wear and tear, such as paint discoloration or chipping, worn or torn gasketing, corroded or cracked logs, embers, etc. Also excluded is damage to the unit caused by abuse, improper installation, modification of the unit, drilling of the orifices, or the use of fuel other than that for which the unit is configured. Units are shipped for natural gas and must be converted to propane using the included conversion kit. Confirm fuel configuration with your installer.
- Damage to gold or nickel surfaces caused by fingerprints, scratches, melted items, or other external sources left on the gold or nickel from the use of cleaners other than denatured alcohol is not covered in this warranty.
- DRAGON WHOLESALING is free of liability for any damages caused by the appliance, as well as inconvenience expenses and materials. Incidental or consequential damages are not covered by this warranty. In some states, the exclusion of incidental or consequential damage may not apply.
- This warranty does not cover any loss or damage incurred by the use or removal of any component or apparatus to or from the gas appliance without the express written permission of DRAGON WHOLESALING and bearing a DRAGON WHOLESALING label of approval.
- Any statement or representation of DRAGON WHOLESALING products and their performance contained in DRAGON WHOLESALING advertising, packaging literature, or printed material is not part of this 7 year warranty.
- This warranty is automatically voided if the appliance's serial number has been removed or altered in any way. If the appliance is used for commercial purposes, it is excluded from this warranty.
- No dealer, distributor, or similar person has the authority to represent or warrant DRAGON WHOLESALING products beyond the terms contained within this warranty. DRAGON WHOLESALING assumes no liability for such warranties or representations.
- Dragon Wholesaling will not cover the cost of the removal or re-installation of hearths, facing, mantels, venting or other components.
- If for any reason any section of this warranty is declared invalid, the balance of the warranty remains in effect and all other clauses shall remain in effect.
- THIS 7 YEAR WARRANTY IS THE ONLY WARRANTY SUPPLIED BY DRAGON WHOLESALING, THE MANUFACTURER OF THE APPLIANCE. ALL OTHER WARRANTIES, WHETHER EXPRESS OR IMPLIED, ARE HEREBY EXPRESSLY DISCLAIMED AND PURCHASER'S RECOURSE IS EXPRESSLY LIMITED TO THE WARRANTIES SET FORTH HEREIN.**

IF WARRANTY SERVICE IS NEEDED:

- If you discover a problem that you believe is covered by this warranty, you **MUST REPORT** it to your DRAGON WHOLESALING dealer **WITHIN 30 DAYS**, giving them proof of purchase, the purchase date, and the model name and serial number.
- Dragon Wholesaling has the option of either repairing or replacing the defective component.
- If your dealer is unable to repair your appliance's defect, he may process a warranty claim through DRAGON WHOLESALING, including the name of the dealership where you purchased the appliance, a copy of your receipt showing the date of the appliance's purchase, and the serial number on your appliance. At that time, you may be asked to ship your appliance, freight charges prepaid, to DRAGON WHOLESALING. DRAGON WHOLESALING, at its option, will repair or replace, free of charge, your DRAGON WHOLESALING appliance if it is found to be defective in material or workmanship within the time frame stated within this 7 year warranty. DRAGON WHOLESALING will return your appliance, freight charges (years 1 to 5) prepaid by DRAGON WHOLESALING, to your regional distributor, or dealership.
- Check with your dealer in advance for any costs to you when arranging a warranty call. Mileage or service charges are not covered by this warranty. This charge can vary from store to store.

LP Conversion Instructions

The GSR Stepper Motor Kit (SKU 94400999) is required for converting this appliance to LP. The kit contains the stepper motor (regulator), torx wrench, and pilot orifice. The burner orifices and burner gaskets are shipped with the appliance.

WARNING:

This conversion kit shall be installed by a qualified service agency in accordance with the manufacturer's instructions and all applicable codes and requirements of the authority having jurisdiction. If the information in these instructions is not followed exactly, a fire, explosion or production of carbon monoxide may result causing property damage, personal injury or loss of life. The qualified service agency is responsible for the proper installation of this kit. The installation is not proper and complete until the operation of the converted appliance is checked as specified in the manufacturer's instructions supplied with the kit.

CAUTION:

The gas supply shall be shut off prior to disconnecting the electrical power, before proceeding with the conversion.

IMPORTANT:

A converted appliance must have a label attached marked with the following:

"This appliance was converted to _____ gas with Kit No. _____ by _____ (name and address of organization making the conversion), which accepts the responsibility that this conversion has been properly made. This control has been converted for use with gas _____."

Convert the appliance prior to installing the gas line to ensure proper gas use.

1. Access the firebox.
2. Remove the manifold cover to access the burner orifices (see below).

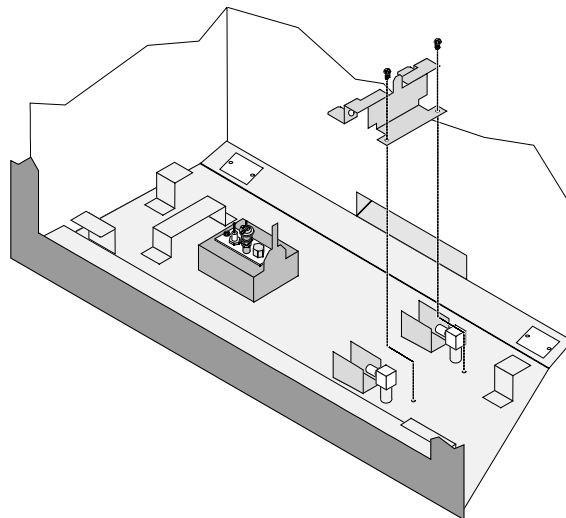

3. Install the LP (propane) orifices.

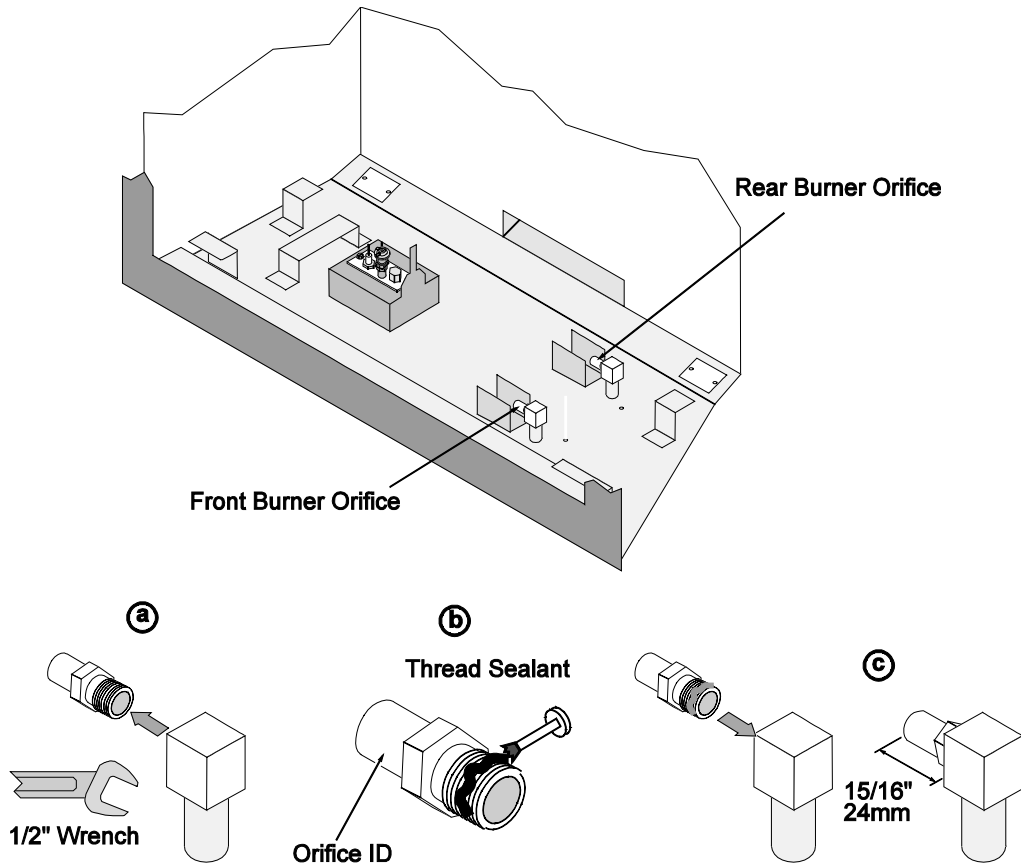

<u>ORIFICE SIZE (ID)</u>	Natural Gas	LP (Propane)
Front Burner Orifice	#50 DMS	#58 DMS
Rear Burner Orifice	#47 DMS	#56 DMS

4. Replace the manifold cover.

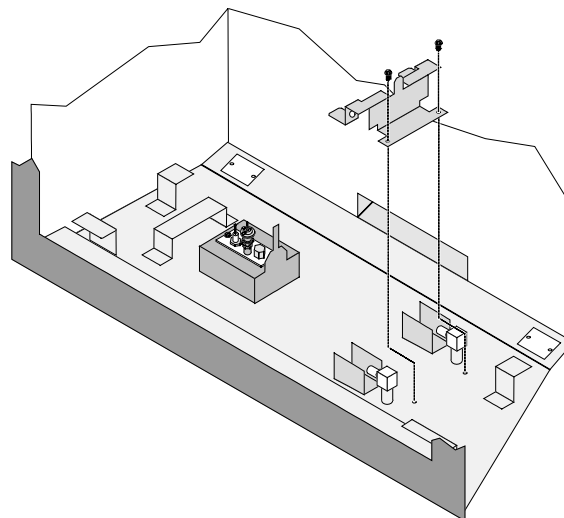

5. Install the LP pilot orifice following the directions below.
 - (a) Use a 7/16" open-end wrench to remove the pilot hood.
 - (b) Remove and discard the Natural Gas (NG) orifice. Place the LP orifice in the pilot assembly then replace the pilot hood, tightening the pilot hood until it is snug (do not over-tighten).

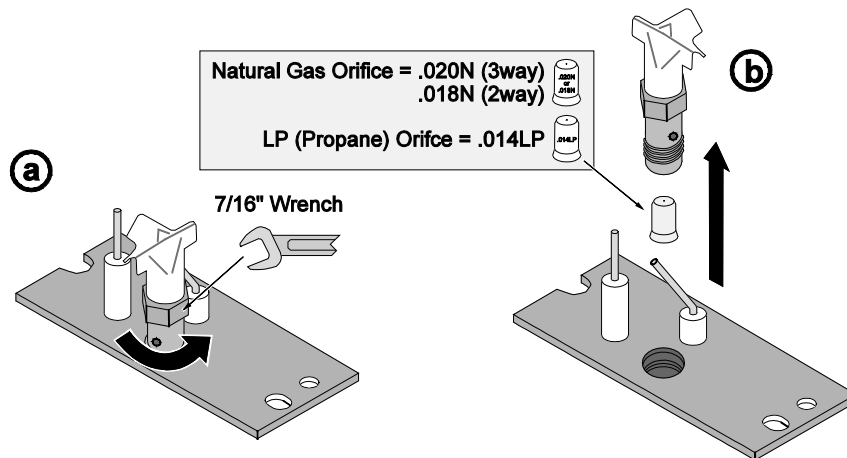

6. Replace the firebox components.
7. The stepper motor (adjustable regulator) has an installation sheet included with it – make sure to follow all the directions. Disconnect the wiring from the stepper motor. Remove the stock stepper motor and replace with the LP version – **MAKE SURE IT IS CORRECTLY ORIENTED**. Secure using the screws included with the motor, and tighten to 25 Lb-inches. Leak-test this area after installing to verify proper installation. Re-attach the wiring.



8. Restore the appliance to the correct configuration. Make the gas line connection, bleed the gas line (if applicable), start the heater and thoroughly leak-test all gas connections and the gas control valve.

Accent Light Replacement	35	Low Battery Indicator	33
Additional Items Required	8	Lower Accent Light	35
Battery Replacement.....	33	LP Conversion Instructions.....	41
Before You Begin	25	Maintaining Your Heater's Appearance	35
Child-Proof Feature.....	34	Modifying the Face Connector for Discovery, Rosario, and Artisan Faces	12
Clearances	12	Normal Operating Odors.....	34
Continuous/Intermittent Pilot Switch	28	Normal Operating Sounds	34
Dimensions.....	6	Order of Installation.....	8
Direct Operation	27	Packing List.....	7
Display Fahrenheit or Celsius	32	Power Outages	33
Electrical Requirements	11	Remote Control Warnings	25
Features	6	Remote Operation.....	29
Fireplace Altered Tag.....	10	Remote Set-Up	26
Fireplace Requirements	9	Replacement Parts List.....	38
Fuel	6	Starting the Fireplace for the First Time	28
Gas Line Requirements	13	Steps for Finalizing the Installation	23
Glass Frame Removal and Installation	21	Surround Panel Installation.....	19
Hearth Requirements	10	Top Convection Deflector	9
Heating Specifications.....	6	Troubleshooting Table	37
Installation Options.....	6	Vent Requirements	14
Installation Warnings.....	7	Wiring Diagram	38
Items Packed with the Face.....	8	Yearly Service Procedure	36
Leveling Bolts	11		
Location of Controls	27		