

# LOPI FLUSH WOOD MEDIUM NEX-GEN SPARE PARTS - EFFECTIVE 1 SEPTEMBER 2024

## Door Parts

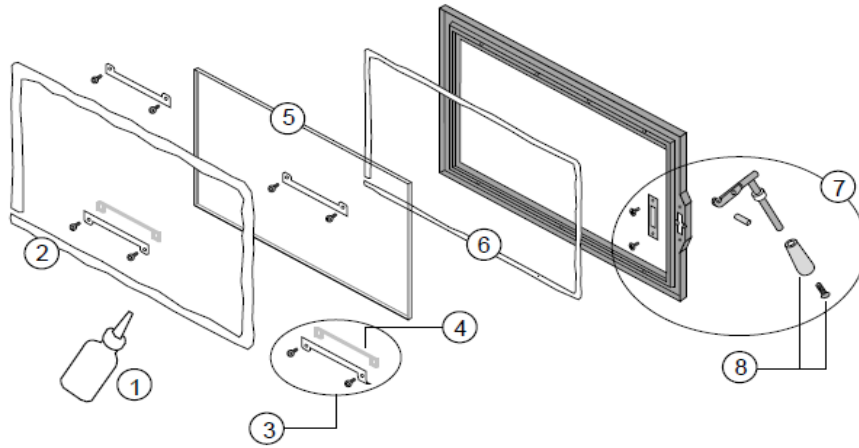

ID #	Description	Qty	Part #	\$	Other Detail
1	Gasket Cement, 4 oz.	1	250-04477		See your Lopi Dealer
2	Door Gasket, 3/8" x 80"	1	99900429	\$72	
3 and 4	(4) Clips w Screws, Gaskets - Rect.	1	250-02191	\$44	
5	Glass (w Gasket) - Rectangular	1	250-02183	\$320	
6	Glass Gasket (1/4" X 76")	1	250-02184	\$15	
7	Handle Assembly	1	250-02196	\$95	
8	Wood Handle w Screw	1	250-01305	\$26	

### Replacing the Glass



The glass must not contact the door retainer or glass clips directly. The glass gasket and glass clip gaskets insulate the glass to prevent cracking. Do not over-tighten the glass clips. Use only 5mm thick neo-ceramic glass.

Lay the glass gasket in the doorframe (cut off excess gasket). Place the glass on the gasket. Secure the glass clips to hold the glass in place (make sure the glass clip gaskets are in place).

### Replacing the Door Gasket

The door gasket inbuilds into the outer groove of the door retainer. Stove gasket cement holds it in place. Before installing, remove any residual cement. Lay the gasket in place (start at the lower left corner) and cut off any excess gasket (do not stretch the gasket. The cement fully cures with heat from the stove. You may need to open and close the door repeatedly to get the gasket to seat fully.

**Firebox Parts**

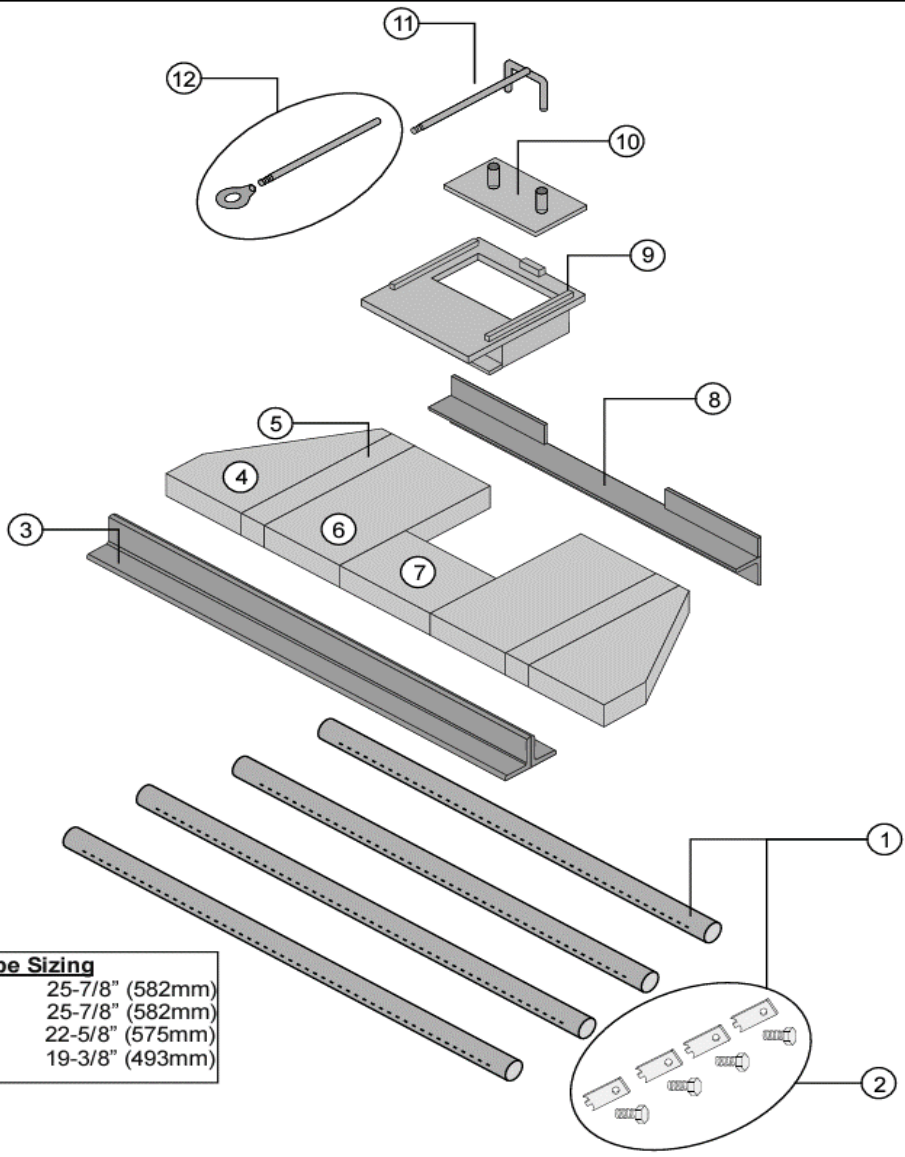

<b>Tube Sizing</b>	
Tube #1 (Front)	25-7/8" (582mm)
Tube #2	25-7/8" (582mm)
Tube #3	22-5/8" (575mm)
Tube #4 (Rear)	19-3/8" (493mm)

ID #	Description	Qty	Part #	\$	Other Detail
1	Sec. Air Tubes w Pins (all 4)	1	98900258	\$166	
2	Air Tube Pin (w Screw)	4	250-02186	\$15	
3	Front Baffle Support	1	250-05505	TBA - Call	
4	Brick, Cut 9" x 2-1/2" x 3/16"	2	251-00089	\$27	each
5	Brick, Cut 9" x 1-3/8"	1	251-00018	\$27	each
6	Brick, Full 9" x 4"	1	251-00000	\$27	each
7	Brick, Cut 4" x 5-1/2"	1	251-00090	\$27	each
8	Rear Baffle Support	1	250-05506	TBA - Call	
9	Damper Slide Plate	1	250-05504	TBA - Call	
10	Damper Slider	1	250-03596	\$87	
11	Yoke	1	98900331	\$53	
12	Damper Extension Rod & Ring	1	98900333	\$68	