

FLUSHWOOD SMALL SPARE PARTS (DISCONTINUED) - MARCH 2025

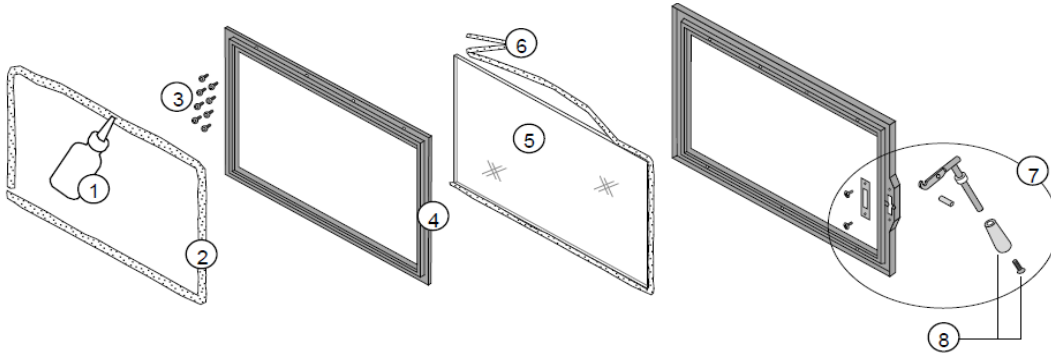

Pricing shown excludes freight and installation. Pricing may vary depending on area.

Pricing includes GST.

ID #	Description	Qty	Part #	\$	Other Detail
1	Gasket Cement, 4oz				See your LOPI Dealer
2	Door Gasket	1	99900429	\$ 75	
3	Glass Retainer Screws (8)	1	250-02967	\$ 30	Pack of 8
4	Glass Retainer	1	250-03052	\$ 139	
5	Glass with Gasket	1	250-03051	\$ 280	
6	Glass Gasket	1	250-02970	\$ 30	
7	Handle Assembly	1	250-02971	\$ 60	
8	Wood Handle with Screw	1	250-01305	\$ 26	

Replacing the Glass



The glass must not contact the door retainer or glass clips directly. The glass gasket and glass clip gaskets insulate the glass to prevent cracking. Do not over-tighten the glass clips. Use only 5mm thick neo-ceramic glass.

Lay the glass gasket in the door frame (cut off excess gasket). Place the glass on the gasket. Secure the glass clips to hold the glass in place (make sure the glass clip gaskets are in place).

Replacing the Door Gasket

The door gasket inserts into the outer groove of the door retainer. Stove gasket cement holds it in place. Before installing, remove any residual cement. Lay the gasket in place (start at the lower left corner) and cut off any excess gasket (do not stretch the gasket. The cement fully cures with heat from the stove. You may need to open and close the door repeatedly to get the gasket to seat fully.

Firebox Parts

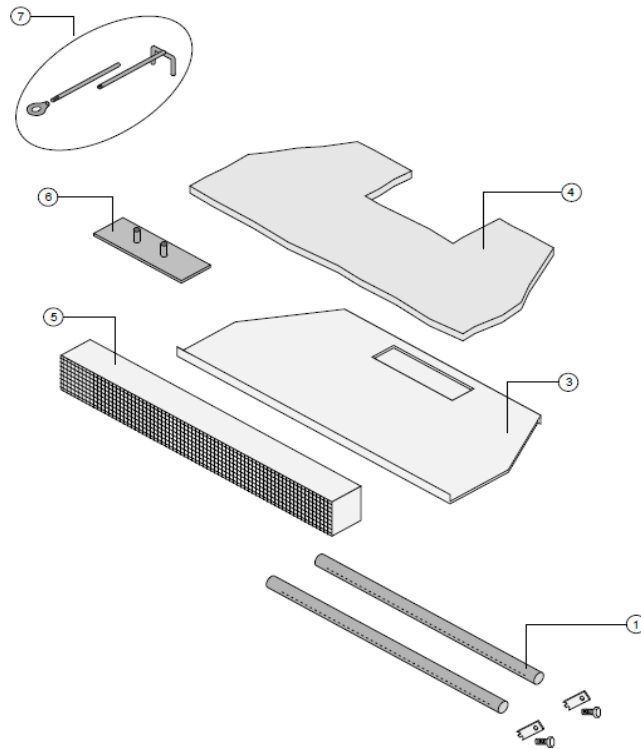

Pricing shown excludes freight and installation. Pricing may vary depending on area.

Pricing includes GST.

ID #	Description	Qty	Part #	\$	Other Detail
1	Secondary Air Tube with Pin L-24 (2)	1	98900246	\$ 113	
3	Baffle Plate	1	250-02973	\$ 135	
4	Baffle Insulation	1	250-02974	\$ 60	
5	Catalytic Combustor with Gasket	1	250-02489	\$ 999	
6	Bypass Slider	1	250-02975	\$ 53	
7	Damper Yoke Assembly	1	250-02976	\$ 105	
7b	Damper Extension Rod	1	250-02977	\$ 30	
8	Combustor Gasket (2)	1	250-02643	\$ 64	

Baffle Removal

- 1 Remove the face to prevent damage. Remove the door (lift off hinges).
- 2 Remove the front two air tubes (see "Air Tube Removal & Replacement" on the following page).
- 3 Remove the baffle plate and insulation.